

TMCM-1310 CoE Firmware Manual

Firmware Version V2.05 | Document Revision V1.00 • 2016-Sep-30

The CANopen Firmware is used in combination with the integrated TMCM-1310 closed loop stepper motor controller module. It implements the FOC2 technology on the TMCM-1310 in conjunction with EtherCAT and the CoE protocol.



Features

- 1-Axis 2-phase stepper motor control
- CiA 402 drive profile
- FOC2 technology

Applications

- Lab-Automation
- Semiconductor Handling
- Manufacturing
- Robotics
- Factory Automation
- CNC
- Laboratory Automation



Contents

1	Preface	6
1.1	General Features of this CoE Implementation	6
1.2	Abbreviations used in this Manual	7
1.3	Firmware Update	7
2	Communication	8
2.1	Reference Model	8
2.2	NMT State Machine	10
2.3	Device Model	11
2.4	Object Dictionary	12
3	Communication area	13
3.1	Detailed object specifications	13
3.1.1	Object 1000 _h : Device Type	13
3.1.2	Object 1001 _h : Error Register	13
3.1.3	Object 1008 _h : Manufacturer Device Name	14
3.1.4	Object 1009 _h : Manufacturer Hardware Version	14
3.1.5	Object 100A _h : Manufacturer Software Version	15
3.1.6	Object 1018 _h : Identity Object	15
3.1.7	Object 1600 _h : Receive PDO Mapping Parameter	16
3.1.8	Objects 1A00 _h : Transmit PDO Mapping Parameter	17
3.1.9	Objects 1C00 _h : Sync Manager Communication Type	17
3.1.10	Objects 1C12 _h : Sync Manager 2 PDO Assignment	18
3.1.11	Objects 1C13 _h : Sync Manager 3 PDO Assignment	19
4	Manufacturer specific area	20
4.1	Objects related to Closed Loop / FOC2 (Overview)	20
4.2	Objects related to coolStep	21
4.3	Detailed object specifications	23
4.3.1	Object 2000 _h : Microstep resolution	23
4.3.2	Object 2001 _h : Fullstep resolution	23
4.3.3	Object 2002 _h : Brake delay times	23
4.3.4	Object 2003 _h : Maximum current	24
4.3.5	Object 2004 _h : Standby current	25
4.3.6	Object 2005 _h : Limit switches	25
4.3.7	Object 200A _h : Enable drive delay time	26
4.3.8	Object 200B _h : Encoder parameters	26
4.3.9	Object 200C _h : Brake current feed	27
4.3.10	Object 2020 _h : Closed-loop Mode	27
4.3.11	Object 2021 _h : Torque P Factor	28
4.3.12	Object 2022 _h : Torque I Factor	28
4.3.13	Object 2023 _h : Velocity P Factor	28
4.3.14	Object 2024 _h : Velocity I Factor	29
4.3.15	Object 2025 _h : Position P Factor	29
4.3.16	Object 2026 _h : Encoder Initialization Mode	30
4.3.17	Object 2027 _h : Closed-loop Beta	30
4.3.18	Object 2028 _h : Minimum Flux Speed	30
4.3.19	Object 2029 _h : Maximum Flux Speed	31
4.3.20	Object 202A _h : Target Flux Share	31
4.3.21	Object 2030 _h : Torque PI Error	32
4.3.22	Object 2031 _h : Torque PI Error Sum	32
4.3.23	Object 2032 _h : Velocity PI Error	32



4.3.24	Object 2033 _h : Velocity PI Error Sum	33
4.3.25	Object 2034 _h : Controlled Angle	33
4.3.26	Object 2035 _h : Last Encoder Angle	34
4.3.27	Object 2036 _h : Phase A Actual Current	34
4.3.28	Object 2037 _h : Phase B Actual Current	34
4.3.29	Object 2038 _h : Actual Supply Voltage	35
4.3.30	Object 2039 _h : Actual Supply Current	35
4.3.31	Object 203A _h : Actual Module Temperature	36
4.3.32	Object 203B _h : Maximum possible motor current	36
4.3.33	Object 208C _h : Velocity Dimension Index	36
4.3.34	Object 208E _h : Acceleration Dimension Index	37
4.3.35	Object 2092 _h : Chopper Blank Time	37
4.3.36	Object 2093 _h : Chopper Mode	38
4.3.37	Object 2094 _h : Chopper Hysteresis Decrement	38
4.3.38	Object 2095 _h : Chopper Hysteresis End	39
4.3.39	Object 2096 _h : Chopper Hysteresis Start	39
4.3.40	Object 2097 _h : Chopper Off Time	40
4.3.41	Object 2098 _h : Smart Energy Current Minimum	40
4.3.42	Object 2099 _h : Smart Energy Current Down Step	41
4.3.43	Object 209A _h : Smart Energy Hysteresis	41
4.3.44	Object 209B _h : Smart Energy Current Up Step	42
4.3.45	Object 209C _h : Smart Energy Hysteresis Start	42
4.3.46	Object 209D _h : Smart Energy Filter Enable	43
4.3.47	Object 209E _h : stallGuard2 Threshold	43
4.3.48	Object 209F _h : Slope Control High Side	44
4.3.49	Object 20A0 _h : Slope Control Low Side	44
4.3.50	Object 20A1 _h : Short Protection Disable	45
4.3.51	Object 20A2 _h : Short Detection Timer	45
4.3.52	Object 20A3 _h : Vsense	45
4.3.53	Object 2100 _h : Home Offset Display	46
4.3.54	Object 2101 _h : Actual Load Value	46
4.3.55	Object 2102 _h : Driver Error Flags	47
4.3.56	Object 2107 _h : Microstep resolution display	47
4.3.57	Object 210B _h : Step Counter	48
4.3.58	Object 2700 _h : TMCL Direct Communication	48
4.3.59	Object 2701 _h : Manufacturer Specific Mode	49
4.3.60	Object 2702 _h : Device Digital Inputs	49
4.3.61	Object 2703 _h : Device Digital Outputs	50
4.3.62	Object 2704 _h : CAN Bit Rate	51
4.3.63	Object 2705 _h : Node ID	51
4.3.64	Object 2706 _h : Store	52
4.3.65	Object 2707 _h : CAN Bit Rate Load	52
4.3.66	Object 2708 _h : Node ID Load	53
4.3.67	Object 270E _h : Device Analog Inputs	53

5	Profile specific area	55
5.1	Detailed object specifications	55
5.1.1	Object 605A _h : Quick stop option code	55
5.1.2	Object 605B _h : Shutdown option code	56
5.1.3	Object 605C _h : Disable operation option code	56
5.1.4	Object 605D _h : Halt option code	57
5.1.5	Object 605E _h : Fault reaction option code	57
5.1.6	Object 6060 _h : Modes of operation	58
5.1.7	Object 6061 _h : Modes of operation	59



5.1.8	Object 606A _h : Sensor selection code	59
5.1.9	Object 608F _h : Position Encoder Resolution	60
5.1.10	Object 60FD _h : Digital Inputs	61
5.1.11	Object 6502 _h : Supported Drive Modes	61
6	Profile position mode	63
6.1	Detailed Object Specifications	63
6.1.1	Object 6040 _h : Control Word	64
6.1.2	Object 6041 _h : Status Word	65
6.1.3	Object 6062 _h : Position Demand Value	66
6.1.4	Object 6063 _h : Position Actual Internal Value	67
6.1.5	Object 6064 _h : Position Actual Internal Value	67
6.1.6	Object 6065 _h : Following Error Window	68
6.1.7	Object 6067 _h : Position Window	68
6.1.8	Object 6068 _h : Position Window Time	69
6.1.9	Object 606C _h : Velocity Actual Value	69
6.1.10	Object 607A _h : Target Position	70
6.1.11	Object 607D _h : Software Position Limit	70
6.1.12	Object 6081 _h : Profile Velocity	71
6.1.13	Object 6082 _h : End Velocity	71
6.1.14	Object 6083 _h : Profile Acceleration	72
6.1.15	Object 6084 _h : Profile Deceleration	72
6.1.16	Object 6085 _h : Quick Stop Deceleration	72
6.1.17	Object 60F2 _h : Positioning Option Code	73
6.2	How to move a Motor in pp Mode	74
7	Profile velocity mode	75
7.1	Detailed Object Specifications	75
7.1.1	Object 6040 _h : Control Word	75
7.1.2	Object 6041 _h : Status Word	76
7.1.3	Object 6062 _h : Position Demand Value	78
7.1.4	Object 6063 _h : Position Actual Internal Value	78
7.1.5	Object 6064 _h : Position Actual Internal Value	79
7.1.6	Object 6065 _h : Following Error Window	79
7.1.7	Object 606C _h : Velocity Actual Value	80
7.1.8	Object 607D _h : Software Position Limit	80
7.1.9	Object 6083 _h : Profile Acceleration	81
7.1.10	Object 6085 _h : Quick Stop Deceleration	81
7.1.11	Object 60FF _h : Target Velocity	81
7.2	How to move a Motor in pv Mode	82
8	Homing mode	83
8.1	Homing Methods	83
8.1.1	Homing Method 1: Homing on negative Limit Switch and Index Pulse	84
8.1.2	Homing Method 2: Homing on positive Limit Switch and Index Pulse	84
8.1.3	Homing Method 3: Homing on positive Home Switch and Index Pulse	85
8.1.4	Homing Method 5: Homing on negative Home Switch and Index Pulse	85
8.1.5	Homing Method 17, 18, 19, and 21: Homing without Index Pulse	86
8.1.6	Homing Method 33 and 34: Homing on next Index Pulse	86
8.1.7	Homing Method 35: Current position as home position	87
8.2	Detailed Object Specifications	88
8.2.1	Object 6040 _h : Control Word	88
8.2.2	Object 6041 _h : Status Word	89
8.2.3	Object 606C _h : Velocity Actual Value	90



8.2.4	Object 607C _h : Home Offset	91
8.2.5	Object 6098 _h : Homing Method	92
8.2.6	Object 6099 _h : Homing Speeds	92
8.2.7	Object 609A _h : Homing Acceleration	92
8.2.8	Object 2100 _h : Home Offset Display	93
8.3	How to start a Homing in hm Mode	93
9	Cyclic synchronous Position Mode	95
9.1	Detailed Object Specifications	95
9.1.1	Object 6040 _h : Control Word	95
9.1.2	Object 6041 _h : Status Word	96
9.1.3	Object 6062 _h : Position Demand Value	98
9.1.4	Object 6063 _h : Position Actual Internal Value	98
9.1.5	Object 6064 _h : Position Actual Internal Value	99
9.1.6	Object 606C _h : Velocity Actual Value	99
9.1.7	Object 607A _h : Target Position	99
9.1.8	Object 607D _h : Software Position Limit	100
9.1.9	Object 60B0 _h : Position Offset	100
9.1.10	Object 60C2 _h : Interpolation Time Period	101
10	Cyclic synchronous Torque Mode	102
10.1	Detailed Object Specifications	102
10.1.1	Object 6040 _h : Control Word	102
10.1.2	Object 6041 _h : Status Word	103
10.1.3	Object 6062 _h : Position Demand Value	104
10.1.4	Object 6063 _h : Position Actual Internal Value	105
10.1.5	Object 6064 _h : Position Actual Internal Value	105
10.1.6	Object 6071 _h : Target Torque	106
10.1.7	Object 6077 _h : Torque actual Value	106
10.1.8	Object 607D _h : Software Position Limit	106
10.1.9	Object 60B2 _h : Torque Offset	107
10.1.10	Object 60C2 _h : Interpolation Time Period	107
11	Emergency Messages (EMCY)	109
12	Figures Index	111
13	Tables Index	112
14	Supplemental Directives	116
14.1	Producer Information	116
14.2	Copyright	116
14.3	Trademark Designations and Symbols	116
14.4	Target User	116
14.5	Disclaimer: Life Support Systems	116
14.6	Disclaimer: Intended Use	116
14.7	Collateral Documents & Tools	117
15	Revision History	118
15.1	Firmware Revision	118
15.2	Document Revision	118



1 Preface

This document specifies objects and modes of operation of the Trinamic TMC-1310 stepper motor control module with CANopen-over-EtherCAT (CoE) firmware. The CoE firmware is designed to fulfill the EtherCAT version of the CANopen DS402 standards. The EtherCAT conformance has also been tested. This manual assumes that the reader is already familiar with the basics of EtherCAT and the CoE protocol (especially DS402).

1.1 General Features of this CoE Implementation

Main Characteristics

- Communication according to EtherCAT standards
- Protocols: CoE

SDO Communication

- 1 server
- Expedited transfer
- Segmented transfer
- No block transfer

PDO Communication

- Producer
- Consumer
- RPDOs
 - Dynamic mapping with max. 9 mapping entries.
 - Default mappings: manufacturer specific.
- TPDOs
 - Dynamic mapping with max. 9 mapping entries.
 - Default mappings: manufacturer specific.

Sync managers

- Sync manager 0: receive mailbox used for SDO communication
- Sync manager 1: send mailbox used for SDO communication
- Sync manager 2: process data output (used for TPDO)
- Sync manager 3: process data input (used for RPDO)

Further Characteristics

- Emergency: producer



1.2 Abbreviations used in this Manual

Abbreviations	
CAN	Controller area network
CoE	CANopen over EtherCAT
CHGND	chassis ground / earth ground
COB	Communication object
FoE	File transfer over EtherCAT
FSA	Finite state automaton
FSM	Finite state machine
NMT	Network management
ID	Identifier
LSB	Least significant bit
MSB	Most significant bit
PDO	Process data object
PDS	Power drive system
RPDO	Receive process data object
SDO	Service data object
TPDO	Transmit process data object
EMCY	Emergency object
rw	Read and write
ro	Read only
hm	Homing mode
pp	Profile position mode
pv	Profile velocity mode
vm	Velocity mode

Table 1: Abbreviations used in this Manual

1.3 Firmware Update

The software running on the microprocessor consists of two parts, a boot loader and the CoE firmware itself. Whereas the boot loader is installed during production and testing at TRINAMIC and remains untouched throughout the whole lifetime, the CoE firmware can easily be updated by the user. The new firmware can be loaded into the module via the firmware update function of the TMCL-IDE, using the USB interface of the module.



2 Communication

2.1 Reference Model

The application layer comprises a concept to configure and communicate real-time-data as well as the mechanisms for synchronization between devices. The functionality which the application layer offers to an application is logically divided over different service data objects (SDO) in the application layer. A service object offers a specific functionality and all the related services.

Applications interact by invoking services of a service object in the application layer. To realize these services this object exchanges data via the EtherCAT with peer service object(s) using a protocol.

The application and the application layer interact with service primitives.

Service Primitives	
Primitive	Definition
Request	Issued by the application to the application layer to request a service.
Indication	Issued by the application layer to the application to report an internal event detected by the application layer or indicate that a service is requested.
Response	Issued by the application to the application layer to respond to a previous received indication.
Confirmation	Issued by the application layer to the application to report the result of a previously issued request.

Table 2: Service Primitives

A service type defines the primitives that are exchanged between the application layer and the cooperating applications for a particular service of a service object. Unconfirmed and confirmed services are collectively called remote services.



Service Types	
Type	Definition
Local service	Involves only the local service object. The application issues a request to its local service object that executes the requested service without communicating with peer service object(s).
Unconfirmed service	Involves one or more peer service objects. The application issues a request to its local service object. This request is transferred to the peer service object(s) that each passes it to their application as an indication. The result is not confirmed back.
Confirmed service	Can involve only one peer service object. The application issues a request to its local service object. This request is transferred to the peer service object that passes it to the other application as an indication. The other application issues a response that is transferred to the originating service object that passes it as a confirmation to the requesting application.
Provider initiated service	Involves only the local service object. The service object (being the service provider) detects an event not solicited by a requested service. This event is then indicated to the application.

Table 3: Service Types



2.2 NMT State Machine

The finite state machine (FSM) or simply state machine is a model of behavior composed of a finite number of states, transitions between those states, and actions. It shows which way the logic runs when certain conditions are met.

Starting and resetting the device is controlled via the state machine. The NMT state machine consists of the states shown in figure 1.

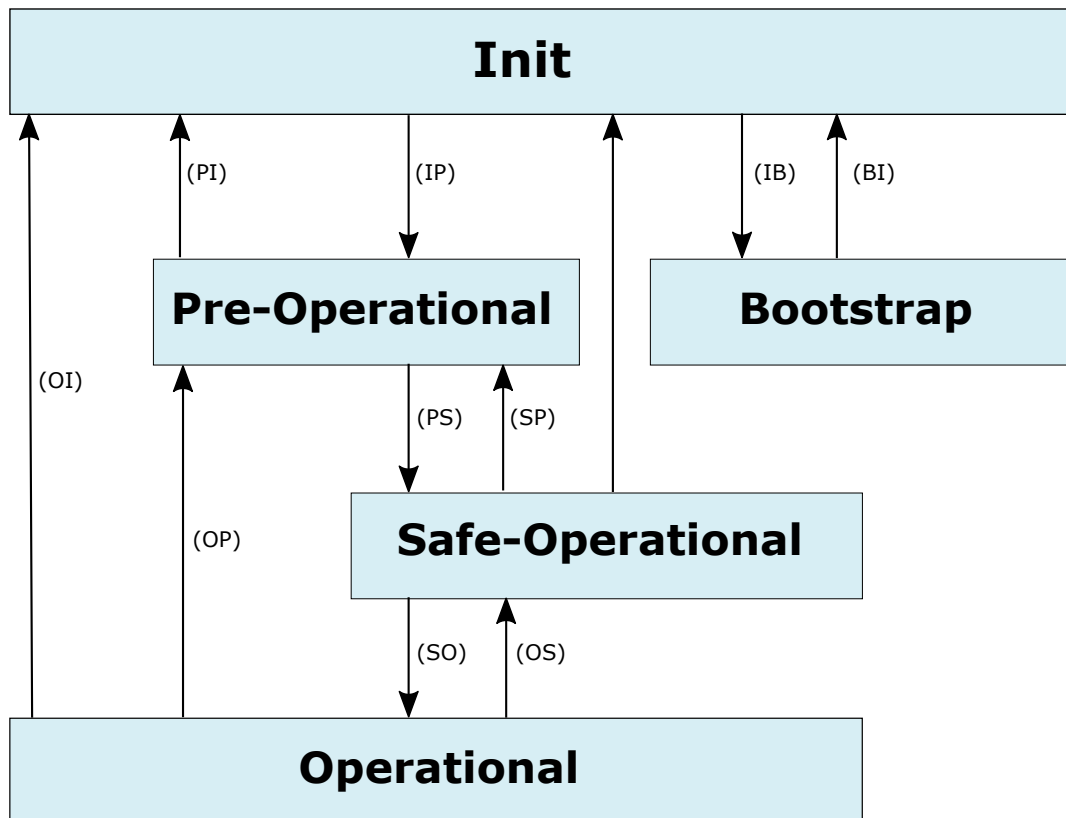

Figure 1: NMT State Machine

After power-on or reset the device enters the Initialization (**INIT**) state.

The master can then switch the device to Pre-Operational (**PRE-OP**) state. In this state, only SDO communication is possible. PDO communication is not possible.

In Safe-Operational (**SAFE-OP**) state, also PDO communication is possible. Inputs can be read, but outputs cannot be switched and the motor cannot be run.

In Operational (**OP**) state, all features of the module can be used. PDO communication is possible, outputs can be switched and the motor can be used. During Operational state the device can use all supported communication objects.

When switching from Operational to Safe-Operational state the motor will be stopped if it has been running. When the EtherCAT connection is lost during Operational state the device will also automatically switch to



Safe-Operational state.

The Bootstrap (**BOOT**) state is used for firmware updates via FoE. Before FoE can be used the device has to be switched to this state.

2.3 Device Model

A CoE device mainly consists of the following parts:

- *Communication*: This function unit provides the communication objects and the appropriate functionality to transport data items via the underlying network structure.
- *Object dictionary*: The object dictionary is a collection of all the data items which have an influence on the behavior of the application objects, the communication objects and the state machine used on this device.
- *Application*: The application comprises the functionality of the device with respect to the interaction with the process environment.

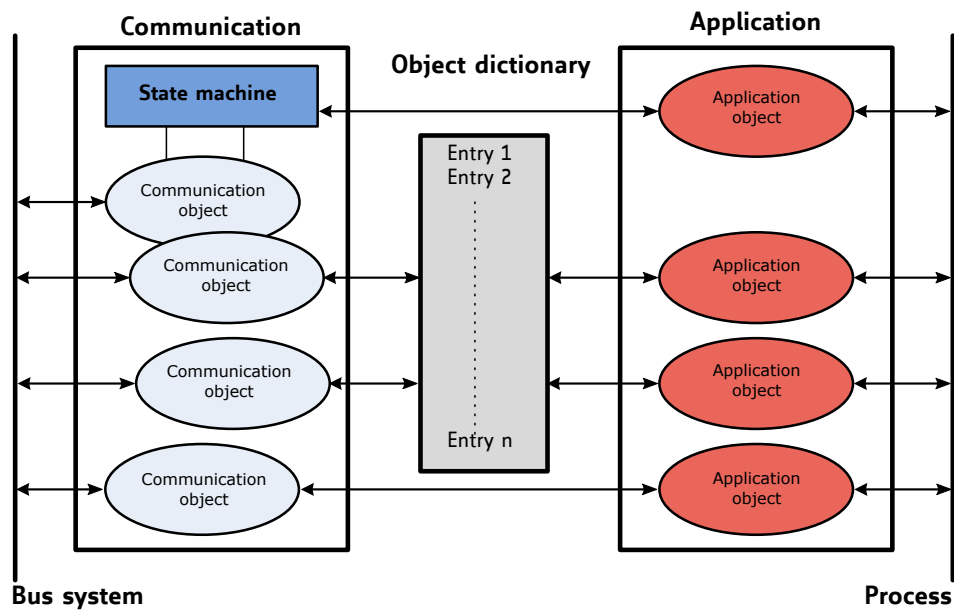

Figure 2: Device Model



2.4 Object Dictionary

The most important part of a device profile is the object dictionary description. The object dictionary is essentially a grouping of objects accessible via the network in an ordered pre-defined fashion. Each object within the dictionary is addressed using a 16-bit index. The overall layout of the standard object dictionary is shown in table 4:

Object Dictionary	
Index	Object
0000 _h	Not used.
0001 _h – 001F _h	Static data types.
0020 _h – 003F _h	Complex data types.
0040 _h – 005F _h	Manufacturer specific complex data types.
0060 _h – 007F _h	Device profile specific static data types.
0080 _h – 009F _h	Device profile specific complex data types.
00A0 _h – 0FFF _h	Reserved for further use.
1000 _h – 1FFF _h	Communication profile area.
2000 _h – 5FFF _h	Manufacturer specific profile area.
6000 _h – 9FFF _h	Standardized device profile area.
A000 _h – BFFF _h	Standardized interface profile area.
C000 _h – FFFF _h	Reserved for further use.

Table 4: Object Dictionary

The communication profile area at indices 1000_h through 1FFF_h contains the communication specific parameters for the CAN network. These entries are common to all devices.

The manufacturer segment at indices 2000_h through 5FFF_h contains manufacturer specific objects. These objects control the special features of the Trinamic TMCM-1310 motion control device.

The standardized device profile area at indices 6000_h through 9FFF_h contains all data objects common to a class of devices that can be read or written via the network. They describe the device parameters and the device functionality of the device profile.



3 Communication area

The communication area contains all objects that define the communication parameters of the CoE device according to the EtherCAT standard.

3.1 Detailed object specifications

3.1.1 Object 1000_h: Device Type

This object contains information about the device type. The object 1000_h describes the type of device and its functionality. It is composed of a 16-bit field which describes the device profile that is used and a second 16-bit field which provides additional information about optional functionality of the device.

Object Description			
Index	Name	Object Type	Data Type
1000 _h	Device type	Variable	UNSIGNED32

Table 5: Object Description (1000_h)

Entry Description				
Sub-index	Access	PDO Mapping	Value Range	Default Value
0	ro	no	UNSIGNED32	FFFC0192 _h

Table 6: Entry Description (1000_h)

3.1.2 Object 1001_h: Error Register

This object contains information about the device type. The object 1000_h describes the type of device and its functionality. It is composed of a 16-bit field which describes the device profile that is used and a second 16-bit field which provides additional information about optional functionality of the device.

Object Description			
Index	Name	Object Type	Data Type
1001 _h	Error register	Variable	UNSIGNED8

Table 7: Object Description (1001_h)

Entry Description				
Sub-index	Access	PDO Mapping	Value Range	Default Value
0	ro	no	UNSIGNED8	0

Table 8: Entry Description (1001_h)



Error Register Bits	
Bit	Definition
0	Generic error
1	Current
2	Voltage
3	Temperature
4	Communication error
5	Device profile specific
6	Reserved (always 0)
7	Manufacturer specific

Table 9: Error Register Bits

3.1.3 Object 1008_h: Manufacturer Device Name

This object contains the manufacturer device name.

Object Description			
Index	Name	Object Type	Data Type
1008 _h	Manufacturer Device Name	Variable	Visible String

Table 10: Object Description (1008_h)

Entry Description				
Sub-index	Access	PDO Mapping	Value Range	Default Value
0	ro	no	—	TMCM-1310

Table 11: Entry Description (1008_h)

3.1.4 Object 1009_h: Manufacturer Hardware Version

This object contains the hardware version description.

Object Description			
Index	Name	Object Type	Data Type
1009 _h	Manufacturer Hardware Version	Variable	Visible String

Table 12: Object Description (1009_h)



Entry Description				
Sub-index	Access	PDO Mapping	Value Range	Default Value
0	ro	no	—	Depends on device, e.g. 1.0.

Table 13: Entry Description (1009_h)

3.1.5 Object 100A_h: Manufacturer Software Version

This object contains the software version description.

Object Description			
Index	Name	Object Type	Data Type
100A _h	Manufacturer Software Version	Variable	Visible String

Table 14: Object Description (100A_h)

Entry Description				
Sub-index	Access	PDO Mapping	Value Range	Default Value
0	ro	no	—	Depends on device, e.g. 1.0.

Table 15: Entry Description (100A_h)

3.1.6 Object 1018_h: Identity Object

The object 1018_h contains general information about the device:

- The vendor ID (sub-index 01_h) contains a unique value allocated to each manufacturer. The vendor ID of Trinamic is 286_h.
- The manufacturer specific product code (sub-index 2_h) identifies a specific device version.
- The manufacturer specific revision number (sub-index 3_h) consists of a major revision number and a minor revision number.

Object Description			
Index	Name	Object Type	Data Type
1018 _h	Identity object	Record	Identity

Table 16: Object Description (1018_h)

Entry Description					
Sub-index	Description	Access	PDO Mapping	Value Range	Default Value
00 _h	Number of entries	ro	no	0...3	3
01 _h	Vendor ID	ro	no	UNSIGNED32	0286 _h
02 _h	Product code	ro	no	UNSIGNED32	1310
03 _h	Revision number	ro	no	UNSIGNED32	e.g. 20003 _h for version 2.3

Table 17: Entry Description (1018_h)

3.1.7 Object 1600_h: Receive PDO Mapping Parameter

This object contains the mapping parameters for the RPDO the device is able to receive. The sub-index 00_h contains the number of valid entries within the mapping record. This number of entries is also the number of the application variables which shall be received with the corresponding RPDO. The sub-indices from 01_h to the number of entries contain the information about the mapped application variables. These entries describe the PDO contents by their index, sub-index and length.

Object Description			
Index	Name	Object Type	Data Type
1600 _h	Receive PDO mapping parameter	RECORD	PDO Mapping

Table 18: Object Description (1600_h)

Entry Description				
Sub-index	Description	Access	Value Range	Default Value
00 _h	Number of mapped application objects in PDO	rw	0...9	Index 1600 _h : 4
01 _h	Mapping entry 1	rw	UNSIGNED32	60400010 _h
02 _h	Mapping entry 3	rw	UNSIGNED32	607A0020 _h
03 _h	Mapping entry 4	rw	UNSIGNED32	60710010 _h
04 _h	Mapping entry 5	rw	UNSIGNED32	60FF0020 _h
05 _h	Mapping entry 2	rw	UNSIGNED32	0 _h
06 _h	Mapping entry 6	rw	UNSIGNED32	0 _h
07 _h	Mapping entry 7	rw	UNSIGNED32	0 _h
08 _h	Mapping entry 8	rw	UNSIGNED32	0 _h
09 _h	Mapping entry 9	rw	UNSIGNED32	0 _h

Table 19: Entry Description (1600_h)



3.1.8 Objects 1A00_h: Transmit PDO Mapping Parameter

This object contains the mapping parameters for the TPDO the device is able to transmit. The sub-index 00_h contains the number of valid entries within the mapping record. This number of entries is also the number of the application variables which shall be transmitted with the corresponding TPDO. The sub-indices from 01_h to the number of entries contain the information about the mapped application variables. These entries describe the PDO contents by their index, sub-index and length.

Object Description			
Index	Name	Object Type	Data Type
1A00 _h	Transmit PDO mapping parameter	RECORD	PDO Mapping

Table 20: Object Description (1A00_h)

Entry Description				
Sub-index	Description	Access	Value Range	Default Value
00 _h	Number of mapped application objects in PDO	rw	0...9	6
01 _h	Mapping entry 1	rw	UNSIGNED32	60410010 _h
02 _h	Mapping entry 2	rw	UNSIGNED32	60610008 _h
03 _h	Mapping entry 3	rw	UNSIGNED32	60640020 _h
04 _h	Mapping entry 4	rw	UNSIGNED32	60770010 _h
05 _h	Mapping entry 5	rw	UNSIGNED32	606C0020 _h
06 _h	Mapping entry 6	rw	UNSIGNED32	60FD0020 _h
07 _h	Mapping entry 7	rw	UNSIGNED32	0 _h
08 _h	Mapping entry 8	rw	UNSIGNED32	0 _h
09 _h	Mapping entry 9	rw	UNSIGNED32	0 _h

Table 21: Entry Description (1A00_h)

3.1.9 Objects 1C00_h: Sync Manager Communication Type

This object describes the communication types of the EtherCAT sync managers. The types of the first four synch managers are normally fixed and should not be changed. Sync managers can have the following for communication types:



Sync Manager Communication Types	
Type	Description
1	Mailbox receive
2	Mailbox send
3	Process data input
4	Process data output

Table 22: Sync Manager Communication Types

Object Description			
Index	Name	Object Type	Data Type
1C00 _h	Sync manager communication type	RECORD	UNSIGNED8

Table 23: Object Description (1C00_h)

Entry Description				
Sub-index	Description	Access	Value Range	Default Value
00 _h	Number of entries	rw	0...3	4
01 _h	Communication type sync manager 1	rw	UNSIGNED8	1
02 _h	Communication type sync manager 2	rw	UNSIGNED8	2
03 _h	Communication type sync manager 3	rw	UNSIGNED8	3
04 _h	Communication type sync manager 4	rw	UNSIGNED8	4

Table 24: Entry Description (1C00_h)

3.1.10 Objects 1C12_h: Sync Manager 2 PDO Assignment

This object contains the index of the PDO definition object that is assigned to sync manager 2. Normally, the RPDO objects are assigned to sync manager 2. Under most circumstances there is no need to change this setting.

Object Description			
Index	Name	Object Type	Data Type
1C12 _h	Sync manager 2 PDO assignment	RECORD	PDO assignment

Table 25: Object Description (1C12_h)



Entry Description				
Sub-index	Description	Access	Value Range	Default Value
00 _h	Number of assigned PDOs	rw	0...1	1
01 _h	PDO mapping index of assigned RPDO	rw	UNSIGNED16	1600 _h

Table 26: Entry Description (1C12_h)

3.1.11 Objects 1C13_h: Sync Manager 3 PDO Assignment

This object contains the index of the PDO definition object that is assigned to sync manager 3. Normally, the TPDO objects are assigned to sync manager 3. Under most circumstances there is no need to change this setting.

Object Description			
Index	Name	Object Type	Data Type
1C13 _h	Sync manager 3 PDO assignment	RECORD	PDO assignment

Table 27: Object Description (1C13_h)

Entry Description				
Sub-index	Description	Access	Value Range	Default Value
00 _h	Number of assigned PDOs	rw	0...1	1
01 _h	PDO mapping index of assigned TPDO	rw	UNSIGNED16	1A00 _h

Table 28: Entry Description (1C13_h)

4 Manufacturer specific area

The manufacturer segment contains manufacturer specific objects. These objects control the special features of the Trinamic Motion Control device TMCM-1310.

4.1 Objects related to Closed Loop / FOC2 (Overview)

The following table presents an overview of all manufacturer specific objects that are related to Closed Loop / FOC2 operation. Please see the following sections for a description of each object.

Closed Loop / FOC2 related Objects		
Object	Name	Description
2020 _h	Closed loop	This object selects closed loop or open loop operation. Set it to 1 for closed loop operation.
2021 _h	Torque P factor	The P factor of the torque PI regulator.
2022 _h	Torque I factor	The I factor of the torque PI regulator.
2023 _h	Velocity P factor	The P factor of the velocity PI regulator.
2024 _h	Velocity I factor	The I factor of the velocity PI regulator.
2025 _h	Position P factor	The P factor of the position P regulator.
2026 _h	Encoder initialization mode	Encoder initialization mode to be used with closed loop operation.
2027 _h	Closed loop beta	Closed loop commutation angle.
2028 _h	Minimum flux speed	Minimum flux speed.
2029 _h	Maximum flux speed	Maximum flux speed.
202A _h	Target flux share	Target flux share.
2030 _h	Torque PI error	This read only object shows the actual error of the torque PI regulator.
2031 _h	Torque PU error sum	This read only object shows the actual error sum of the torque PI regulator.
2032 _h	Velocity PI error	Shows the actual error of the velocity PI regulator.
2033 _h	Velocity PI error sum	Shows the actual error of the velocity PI regulator.
2034 _h	Controlled angle	Shows the actual controlled angle.
2035 _h	Last encoder angle	Shows the last encoder angle.
2036 _h	Phase A actual current	Shows the actual current in motor coil A.
2037 _h	Phase B actual current	Shows the actual current in motor coil B.
2038 _h	Actual supply voltage	Shows the actual supply voltage (in units of 1/10V).
2039 _h	Actual supply current	Shows the actual supply current (mA).
203A _h	Actual module temperature	Shows the actual temperature of the module (°C).



Object	Name	Description
203B _h	Maximum possible motor current	This object shows the maximum current in mA that is possible with the actual settings of objects 2003 _h and 20A3 _h .

Table 29: Closed Loop / FOC2 related Objects

4.2 Objects related to coolStep

Figure 3 shows an overview of the coolStep related objects for motor #0. Please bear in mind that the figure only shows one example for a drive. There are objects which concern the configuration of the current. Other objects are for velocity regulation and for time adjustment. The coolStep feature is sometimes also called smartEnergy.

The following adjustments have to be made:

- Thresholds for current and velocity have to be identified and set.
- The stallGuard2 feature has to be adjusted and enabled.
- The reduction or increasing of the current in the coolStep area (depending on the load) has to be configured.

coolStep™ adjustment points and thresholds

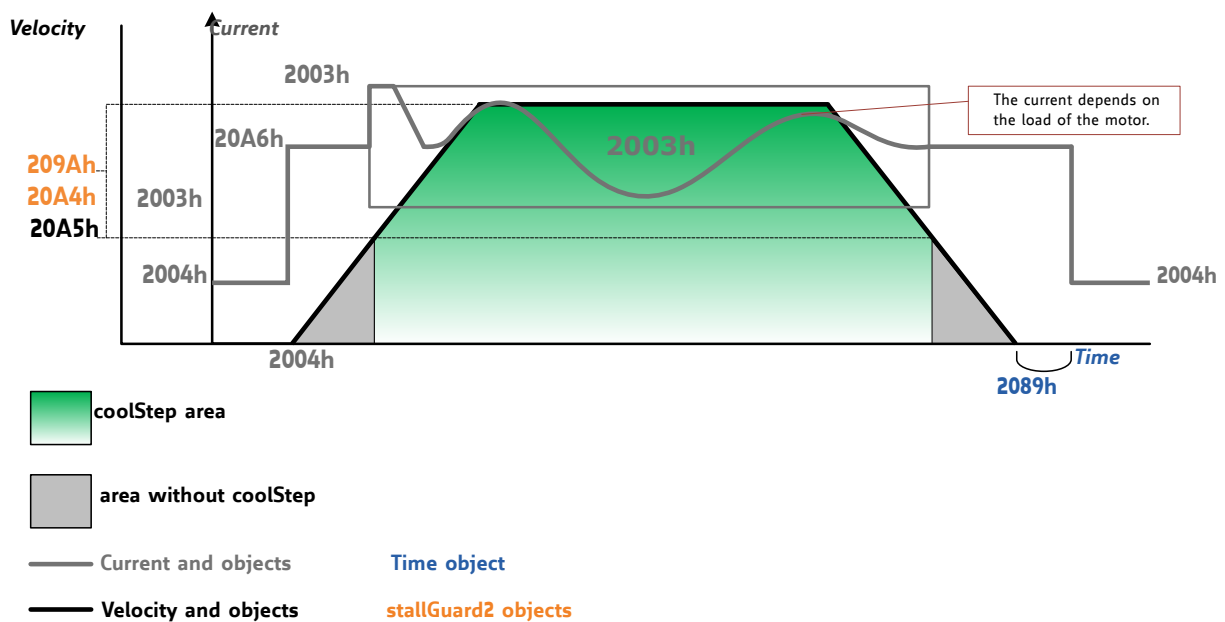

Figure 3: coolStep Adjustment Points and Thresholds



coolStep Adjustment Objects		
Object	Name	Description
2003 _h	Absolute maximum current	The maximum value is 255. This value means 100% of the maximum current of the module. The current adjustment is within the range 0...255 and can be adjusted in 32 steps (0...255 divided by eight; step 0 = 0...7, step 1 = 8...15 and so on). The most important motor setting, since too high values might cause motor damage!
2004 _h	Standby current	The current limit two seconds after the motor has stopped.
2098 _h	smartEnergy current minimum	Sets the lower motor current limit for coolStep operation by scaling the run current (object 2003 _h) value. This can be: 0: for 1/2 of the run current 1: for 1/4 of the run current
2099 _h	smartEnergy current down step	Sets the speed of current decrement when the stallGuard reading is above the upper threshold. 0: slow decrement 3: fast decrement
209B _h	smartEnergy current up step	Sets the current increment step when the stallGuard below the lower threshold. 0: slow increment 3: fast increment / fast reaction to rising load
209A _h	smartEnergy hysteresis	Sets the distance between the lower and the upper threshold for stallGuard2 reading. Above the upper threshold the motor current becomes decreased.
20A4 _h	Stop on stall	Below this speed the motor will not be stopped. Above this speed the motor will stop in case stallGuard2 load value reaches zero.
20A5 _h	smartEnergy threshold speed.	Above this speed coolStep becomes enabled.
2089 _h	Standby delay	Standstill period before the current is changed down to standby current. The standard value is 200 which is 2 seconds.

Table 30: coolStep related Objects



4.3 Detailed object specifications

4.3.1 Object 2000_h: Microstep resolution

This object sets the microstep resolution of the drive. A value of 8 selects 256 (2⁸) microsteps per full step.

Object Description			
Index	Name	Object Type	Data Type
2000 _h	Microstep Resolution	Variable	UNSIGNED8

Table 31: Object Description (2000_h)

Entry Description				
Sub-index	Access	PDO Mapping	Value Range	Default Value
0	rw	no	0...8	8

Table 32: Entry Description (2000_h)

4.3.2 Object 2001_h: Fullstep resolution

This object sets the fullstep resolution of the motor connected to the drive. Its default value is 200 because most motors are 1.8° motors.

Object Description			
Index	Name	Object Type	Data Type
2001 _h	Motor full step resolution	Variable	UNSIGNED16

Table 33: Object Description (2001_h)

Entry Description				
Sub-index	Access	PDO Mapping	Value Range	Default Value
0	rw	no	0...65535	200

Table 34: Entry Description (2001_h)

4.3.3 Object 2002_h: Brake delay times

With this object the delay times for applying and releasing an (optional) brake can be defined. Please see also object 200Ah for an additional delay between enabling the power stage and releasing the brake. Both times are given in ms.



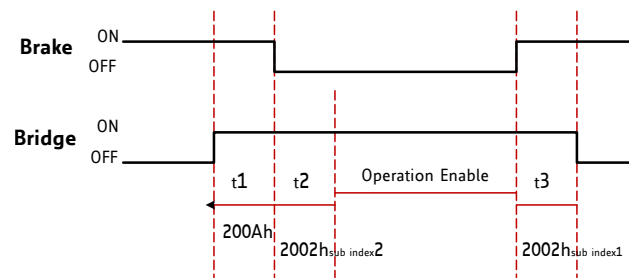

Figure 4: Brake Output Timing

Object Description			
Index	Name	Object Type	Data Type
2002 _h	Brake delay times	Array	UNSIGNED16

Table 35: Object Description (2002_h)

Entry Description					
Sub-index	Description	Access	PDO Mapping	Value Range	Default Value
1	Time between applying brake / disabling power stage	rw	no	0...65535	0
2	Time between releasing brake / switching the state machine to operational	rw	no	0..65535	0

Table 36: Entry Description (2002_h)

4.3.4 Object 2003_h: Maximum current

This object defines the current used when the motor is moving. A value of 255 means 100% of the maximum current of the drive.

Object Description			
Index	Name	Object Type	Data Type
2003 _h	Maximum current	Variable	UNSIGNED8

Table 37: Object Description (2003_h)

Entry Description				
Sub-index	Access	PDO Mapping	Value Range	Default Value
0	rw	no	0...255	128

Table 38: Entry Description (2003_h)



4.3.5 Object 2004_h: Standby current

This object defines the current used when the motor is standing (two seconds after the last move). A value of 255 means 100% of the maximum current of the drive.

Object Description			
Index	Name	Object Type	Data Type
2004 _h	Maximum current	Variable	UNSIGNED8

Table 39: Object Description (2004_h)

Entry Description				
Sub-index	Access	PDO Mapping	Value Range	Default Value
0	rw	no	0...255	8

Table 40: Entry Description (2004_h)

4.3.6 Object 2005_h: Limit switches

This object defines which limit switches are to be used. Bit 0 stands for the left and bit 1 stands for the right limit switch. If a bit is set, the corresponding limit switch will not be used. So this object has to be set to the value 3 if limit switches are not connected. The object can only be written when the drive is in the SWITCHED_ON_DISABLED state (but is always readable).

The limit switches can also be inverted using bit 2 and bit 3:

- Bit 2 inverts the left limit switch
- Bit 3 inverts the right limit switch

Object Description			
Index	Name	Object Type	Data Type
2005 _h	Limit switches	Variable	UNSIGNED32

Table 41: Object Description (2005_h)

Entry Description				
Sub-index	Access	PDO Mapping	Value Range	Default Value
0	rw	no	0...63	0

Table 42: Entry Description (2005_h)



Bit Definitions	
Bit	Definition
0	Left limit switch deactivated, if set.
1	Right limit switch deactivated, if set.
2	Left limit switch inverted, if set.
3	Right limit switch inverted, if set.
4	Home switch deactivated, if set.
5	Home switch inverted, if set.

Table 43: Bit Definitions (2005_h)

4.3.7 Object 200A_h: Enable drive delay time

This is an additional delay time (in milliseconds) between enabling the power stage and releasing the brake. It can be used to prevent the brake from being released too early (before the hold current in the motor has been reached). Please see also object 4.3.3.

Object Description			
Index	Name	Object Type	Data Type
200A _h	Enable drive delay time	Variable	UNSIGNED16

Table 44: Object Description (200A_h)

Entry Description				
Sub-index	Access	PDO Mapping	Value Range	Default Value
0	rw	no	0...65535	0

Table 45: Entry Description (200A_h)

4.3.8 Object 200B_h: Encoder parameters

This object defines encoder parameters. These are the polarity of the encoder null channel, the direction of rotation (set it to 1 if the direction is reversed compared to the motor) and if the position is to be initialized with the encoder position. It is only writable in SWITCHED_ON_DISABLED state.

Object Description			
Index	Name	Object Type	Data Type
200B _h	Encoder parameters	Array	UNSIGNED8

Table 46: Object Description (200B_h)

Entry Description					
Sub-index	Description	Access	PDO Mapping	Value Range	Default Value
1	Null channel polarity	rw	no	0/1	0
2	Direction of rotation	rw	no	0/1	0
3	Initialize position	rw	no	0/1	1

Table 47: Entry Description (200B_h)

4.3.9 Object 200C_h: Brake current feed

This object configures how much current has to be fed into the brake to apply and to release it. 0 means 0 (the module). In most cases it is needed to feed current into the brake to release it. Setting both values to 0 disables the automatic brake control. This object is only writable in SWITCHED_ON_DISABLED state.

Object Description			
Index	Name	Object Type	Data Type
200C _h	Brake current feed	Array	UNSIGNED8

Table 48: Object Description (200C_h)

Entry Description					
Sub-index	Description	Access	PDO Mapping	Value Range	Default Value
1	Apply current	rw	no	0...255	0
2	Release current	rw	no	0...255	0

Table 49: Entry Description (200C_h)

4.3.10 Object 2020_h: Closed-loop Mode

Setting this object to 1 selects closed-loop mode, setting it to 0 (default value) selects open-loop mode. Before activating closed-loop mode, all necessary parameters must have been set.

Object Description			
Index	Name	Object Type	Data Type
2020 _h	Closed-loop mode	Variable	UNSIGNED8

Table 50: Object Description (2020_h)

Entry Description				
Sub-index	Access	PDO Mapping	Value Range	Default Value
0	rw	no	0/1	0

Table 51: Entry Description (2020_h)

4.3.11 Object 2021_h: Torque P Factor

This is the P factor of the torque PI regulator.

Object Description			
Index	Name	Object Type	Data Type
2021 _h	Torque P factor	Variable	UNSIGNED16

Table 52: Object Description (2021_h)

Entry Description				
Sub-index	Access	PDO Mapping	Value Range	Default Value
0	rw	no	0...65535	0

Table 53: Entry Description (2021_h)

4.3.12 Object 2022_h: Torque I Factor

This is the I factor of the torque PI regulator.

Object Description			
Index	Name	Object Type	Data Type
2022 _h	Torque I factor	Variable	UNSIGNED16

Table 54: Object Description (2022_h)

Entry Description				
Sub-index	Access	PDO Mapping	Value Range	Default Value
0	rw	no	0...65535	0

Table 55: Entry Description (2022_h)

4.3.13 Object 2023_h: Velocity P Factor

This the P factor of the velocity PI regulator.



Object Description			
Index	Name	Object Type	Data Type
2023 _h	Velocity P factor	Variable	UNSIGNED16

Table 56: Object Description (2023_h)

Entry Description				
Sub-index	Access	PDO Mapping	Value Range	Default Value
0	rw	no	0...65535	—

Table 57: Entry Description (2023_h)

4.3.14 Object 2024_h: Velocity I Factor

This is the I factor of the velocity PI regulator.

Object Description			
Index	Name	Object Type	Data Type
2024 _h	Closed-loop Offset	Variable	UNSIGNED16

Table 58: Object Description (2024_h)

Entry Description				
Sub-index	Access	PDO Mapping	Value Range	Default Value
0	rw	no	0...65535	—

Table 59: Entry Description (2024_h)

4.3.15 Object 2025_h: Position P Factor

This object contains the P factor of the position P regulator.

Object Description			
Index	Name	Object Type	Data Type
2025 _h	Current scaler minimum	Variable	UNSIGNED16

Table 60: Object Description (2025_h)

Entry Description				
Sub-index	Access	PDO Mapping	Value Range	Default Value
0	rw	no	0...65535	—

Table 61: Entry Description (2025_h)

4.3.16 Object 2026_h: Encoder Initialization Mode

This object contains the encoder initialization mode.

Object Description			
Index	Name	Object Type	Data Type
2026 _h	Encoder initialization mode	Variable	UNSIGNED8

Table 62: Object Description (2026_h)

Entry Description				
Sub-index	Access	PDO Mapping	Value Range	Default Value
0	rw	no	0...2	—

Table 63: Entry Description (2026_h)

4.3.17 Object 2027_h: Closed-loop Beta

This object sets the maximum commutation angle that can be used to compensate for an evaluated position deviation.

Object Description			
Index	Name	Object Type	Data Type
2027 _h	Closed-loop beta	Variable	INTEGER16

Table 64: Object Description (2027_h)

Entry Description				
Sub-index	Access	PDO Mapping	Value Range	Default Value
0	rw	no	-32768...32768	0

Table 65: Entry Description (2027_h)

4.3.18 Object 2028_h: Minimum Flux Speed

This object sets the minimum flux speed.



Object Description			
Index	Name	Object Type	Data Type
2028 _h	Minimum flux speed	Variable	UNSIGNED32

Table 66: Object Description (2028_h)

Entry Description				
Sub-index	Access	PDO Mapping	Value Range	Default Value
0	rw	no	0...2147483647	0

Table 67: Entry Description (2028_h)

4.3.19 Object 2029_h: Maximum Flux Speed

This object contains the maximum flux speed.

Object Description			
Index	Name	Object Type	Data Type
2029 _h	Maximum flux speed	Variable	UNSIGNED32

Table 68: Object Description (2029_h)

Entry Description				
Sub-index	Access	PDO Mapping	Value Range	Default Value
0	rw	no	0...2147483647	—

Table 69: Entry Description (2029_h)

4.3.20 Object 202A_h: Target Flux Share

This object contains the target flux share value.

Object Description			
Index	Name	Object Type	Data Type
202A _h	Target flux share	Variable	UNSIGNED32

Table 70: Object Description (202A_h)



Entry Description				
Sub-index	Access	PDO Mapping	Value Range	Default Value
0	rw	no	0...2147483647	—

Table 71: Entry Description (202A_h)

4.3.21 Object 2030_h: Torque PI Error

This read-only object contains the actual error of the torque PI regulator.

Object Description			
Index	Name	Object Type	Data Type
2030 _h	Torque PI error	Variable	INTEGER32

Table 72: Object Description (2030_h)

Entry Description				
Sub-index	Access	PDO Mapping	Value Range	Default Value
0	ro	no	-2147483648...2147483647	—

Table 73: Entry Description (2030_h)

4.3.22 Object 2031_h: Torque PI Error Sum

This read-only object contains the actual error sum of the torque PI regulator.

Object Description			
Index	Name	Object Type	Data Type
2031 _h	Torque PI error sum	Variable	INTEGER32

Table 74: Object Description (2031_h)

Entry Description				
Sub-index	Access	PDO Mapping	Value Range	Default Value
0	ro	no	-2147483648...2147483647	—

Table 75: Entry Description (2031_h)

4.3.23 Object 2032_h: Velocity PI Error

This read-only object shows the actual error of the velocity PI regulator.



Object Description			
Index	Name	Object Type	Data Type
2032 _h	Velocity PI error	Variable	INTEGER32

Table 76: Object Description (2032_h)

Entry Description				
Sub-index	Access	PDO Mapping	Value Range	Default Value
0	ro	no	-2147483648...2147483647	—

Table 77: Entry Description (2032_h)

4.3.24 Object 2033_h: Velocity PI Error Sum

This read-only object contains the error sum of the velocity PI regulator.

Object Description			
Index	Name	Object Type	Data Type
2033 _h	Velocity PI error sum	Variable	INTEGER32

Table 78: Object Description (2033_h)

Entry Description				
Sub-index	Access	PDO Mapping	Value Range	Default Value
0	ro	no	-2147483648...2147483647	-

Table 79: Entry Description (2033_h)

4.3.25 Object 2034_h: Controlled Angle

This read-only object shows the actual controlled angle.

Object Description			
Index	Name	Object Type	Data Type
2034 _h	Controlled angle	Variable	INTEGER32

Table 80: Object Description (2034_h)

Entry Description				
Sub-index	Access	PDO Mapping	Value Range	Default Value
0	ro	no	-2147483648...2147483647	—

Table 81: Entry Description (2034_h)

4.3.26 Object 2035_h: Last Encoder Angle

This read-only object shows the last encoder angle.

Object Description			
Index	Name	Object Type	Data Type
2035 _h	Last encoder angle	Variable	INTEGER32

Table 82: Object Description (2035_h)

Entry Description				
Sub-index	Access	PDO Mapping	Value Range	Default Value
0	ro	no	-2147483648...2147483647	—

Table 83: Entry Description (2035_h)

4.3.27 Object 2036_h: Phase A Actual Current

This read-only object shows the actual current of motor coil A.

Object Description			
Index	Name	Object Type	Data Type
2036 _h	Phase A actual current	Variable	INTEGER32

Table 84: Object Description (2036_h)

Entry Description				
Sub-index	Access	PDO Mapping	Value Range	Default Value
0	ro	no	-2147483648...2147483647	—

Table 85: Entry Description (2036_h)

4.3.28 Object 2037_h: Phase B Actual Current

This read-only object shows the actual current of motor coil B.



Object Description			
Index	Name	Object Type	Data Type
2037 _h	Phase B actual current	Variable	INTEGER32

Table 86: Object Description (2037_h)

Entry Description				
Sub-index	Access	PDO Mapping	Value Range	Default Value
0	ro	no	-2147483648...2147483647	—

Table 87: Entry Description (2037_h)

4.3.29 Object 2038_h: Actual Supply Voltage

This object shows the actual supply voltage of the module. The unit of this value is 1/10V.

Object Description			
Index	Name	Object Type	Data Type
2038 _h	Actual Supply Voltage	Variable	UNSIGNED32

Table 88: Object Description (2038_h)

Entry Description				
Sub-index	Access	PDO Mapping	Value Range	Default Value
0	ro	no	0...2147483647	—

Table 89: Entry Description (2038_h)

4.3.30 Object 2039_h: Actual Supply Current

This read-only object shows the actual supply current of the module. The unit of this value is mA.

Object Description			
Index	Name	Object Type	Data Type
2039 _h	Actual supply current	Variable	UNSIGNED32

Table 90: Object Description (2039_h)

Entry Description				
Sub-index	Access	PDO Mapping	Value Range	Default Value
0	ro	no	0...2147483647	—

Table 91: Entry Description (2039_h)

4.3.31 Object 203A_h: Actual Module Temperature

This read-only object shows the actual temperature of the module. The unit of this value is °C.

Object Description			
Index	Name	Object Type	Data Type
203A _h	Field weakening	Variable	UNSIGNED32

Table 92: Object Description (203A_h)

Entry Description				
Sub-index	Access	PDO Mapping	Value Range	Default Value
0	ro	no	0...2147483647	—

Table 93: Entry Description (203A_h)

4.3.32 Object 203B_h: Maximum possible motor current

This read-only object shows the maximum motor current (in mA) that is possible with the actual settings of object 2003_h (see section 4.3.4) and object 20A3_h (see section 4.3.52).

Object Description			
Index	Name	Object Type	Data Type
203B _h	Maximum possible motor current	Variable	UNSIGNED32

Table 94: Object Description (203B_h)

Entry Description				
Sub-index	Access	PDO Mapping	Value Range	Default Value
0	ro	no	0...2147483647	—

Table 95: Entry Description (203B_h)

4.3.33 Object 208C_h: Velocity Dimension Index

With this object the unit of the velocity can be chosen. This module only supports internal units. So it is always 0 (which selects internal units).



The internal unit of this module is pulses per second [pps].

Object Description			
Index	Name	Object Type	Data Type
208C _h	Velocity Dimension Index	Variable	UNSIGNED8

Table 96: Object Description (208C_h)

Entry Description				
Sub-index	Access	PDO Mapping	Value Range	Default Value
0	rw	no	0	0

Table 97: Entry Description (208C_h)

4.3.34 Object 208E_h: Acceleration Dimension Index

With this object the unit of the acceleration can be chosen. This module only supports internal units. So it is always 0 (which selects internal units).

The internal unit of this module is pulses per second [pps].

Object Description			
Index	Name	Object Type	Data Type
208E _h	Acceleration Dimension Index	Variable	UNSIGNED8

Table 98: Object Description (208E_h)

Entry Description				
Sub-index	Access	PDO Mapping	Value Range	Default Value
0	ro	no	0	0

Table 99: Entry Description (208E_h)

4.3.35 Object 2092_h: Chopper Blank Time

This object serves for selecting the comparator blank time. This time needs to safely cover the switching event and the duration of the ringing on the sense resistor. For low current drivers, a setting of 1 or 2 is good. For higher current applications a setting of 2 or 3 will be required.



Object Description			
Index	Name	Object Type	Data Type
2092 _h	Chopper Blank Time	Variable	UNSIGNED8

Table 100: Object Description (2092_h)

Entry Description				
Sub-index	Access	PDO Mapping	Value Range	Default Value
0	rw	no	0...3	2

Table 101: Entry Description (2092_h)

4.3.36 Object 2093_h: Chopper Mode

Select the chopper mode using this object:

- 0 – spreadCycle chopper
- 1 – classic constant off time chopper

Object Description			
Index	Name	Object Type	Data Type
2093 _h	Chopper Mode	Variable	UNSIGNED8

Table 102: Object Description (2093_h)

Entry Description				
Sub-index	Access	PDO Mapping	Value Range	Default Value
0	rw	no	0/1	0

Table 103: Entry Description (2093_h)

4.3.37 Object 2094_h: Chopper Hysteresis Decrement

This object serves for the hysteresis decrement setting. This setting determines the slope of the hysteresis during on time and during fast decay time.

- 0 – fast decrement
- 3 – very slow decrement

Object Description			
Index	Name	Object Type	Data Type
2094 _h	Chopper Hysteresis Decrement	Variable	UNSIGNED8

Table 104: Object Description (2094_h)

Entry Description				
Sub-index	Access	PDO Mapping	Value Range	Default Value
0	rw	no	0...3	0

Table 105: Entry Description (2094_h)

4.3.38 Object 2095_h: Chopper Hysteresis End

This object provides the setting of the hysteresis end value after a number of decrements. The decrement interval time is controlled by object 2094_h (section 4.3.37).

Possible values are:

- -3...-1 – negative hysteresis end setting
- 0 – zero hysteresis end setting
- 1...12 – positive hysteresis end setting

Object Description			
Index	Name	Object Type	Data Type
2095 _h	Chopper Hysteresis End	Variable	SIGNED8

Table 106: Object Description (2095_h)

Entry Description				
Sub-index	Access	PDO Mapping	Value Range	Default Value
0	rw	no	-3...12	0

Table 107: Entry Description (2095_h)

4.3.39 Object 2096_h: Chopper Hysteresis Start

This object provides the hysteresis start setting. Please notice that this value is an offset to the hysteresis end value.

Object Description			
Index	Name	Object Type	Data Type
2096 _h	Chopper Hysteresis Start	Variable	UNSIGNED8

Table 108: Object Description (2096_h)



Entry Description				
Sub-index	Access	PDO Mapping	Value Range	Default Value
0	rw	no	0...8	3

Table 109: Entry Description (2096_h)

4.3.40 Object 2097_h: Chopper Off Time

The off time setting controls the minimum chopper frequency. Under normal circumstances, an off time within the range of 5 μ s to 20 μ s is used. Off time setting for constant t_{OFF} chopper: $N_{CLK} = 12 + 32 * t_{OFF}$. Minimum is 64 clocks.

Setting this parameter to zero completely disables all driver transistors and so lets the motor free-wheel.

Object Description			
Index	Name	Object Type	Data Type
2097 _h	Chopper Off Time	Variable	UNSIGNED8

Table 110: Object Description (2097_h)

Entry Description				
Sub-index	Access	PDO Mapping	Value Range	Default Value
0	rw	no	0 / 2...15	5

Table 111: Entry Description (2097_h)

4.3.41 Object 2098_h: Smart Energy Current Minimum

This object provides the setting of the lower motor current limit for coolStep operation by scaling the CS value.

Possible values are:

- 0 – 1/2 of maximum motor current setting (section 4.3.4)
- 1 – 1/4 of maximum motor current setting (section 4.3.4)

Object Description			
Index	Name	Object Type	Data Type
2098 _h	Smart Energy Current Minimum	Variable	UNSIGNED8

Table 112: Object Description (2098_h)

Entry Description				
Sub-index	Access	PDO Mapping	Value Range	Default Value
0	rw	no	0/1	0

Table 113: Entry Description (2098_h)

4.3.42 Object 2099_h: Smart Energy Current Down Step

This object provides the setting of the number of stallGuard2 readings above the upper threshold necessary for each current decrement of the motor current.

Possible values are:

- 0 – 32 measurements – slowest decrement
- 1 – 8 measurements
- 2 – 2 measurements
- 3 – 1 measurements – fastest decrement

Object Description			
Index	Name	Object Type	Data Type
2099 _h	Smart Energy Current Down Step	Variable	UNSIGNED8

Table 114: Object Description (2099_h)

Entry Description				
Sub-index	Access	PDO Mapping	Value Range	Default Value
0	rw	no	0...3	0

Table 115: Entry Description (2099_h)

4.3.43 Object 209A_h: Smart Energy Hysteresis

This object sets the distance between the lower and the upper threshold for stallGuard2 reading. Above the upper threshold the motor current becomes decreased.

Hysteresis: (smartEnergy hysteresis value + 1) * 32

Upper stallGuard threshold: (smartEnergy hysteresis start + smartEnergy hysteresis + 1) * 32

Object Description			
Index	Name	Object Type	Data Type
209A _h	Smart Energy Hysteresis	Variable	UNSIGNED8

Table 116: Object Description (209A_h)



Entry Description				
Sub-index	Access	PDO Mapping	Value Range	Default Value
0	rw	no	0...15	0

Table 117: Entry Description (209A_h)

4.3.44 Object 209B_h: Smart Energy Current Up Step

This object sets the current increment step. The current becomes incremented for each measured stallGuard2 value below the lower threshold (see smart energy hysteresis start (object 209C_h, section 4.3.45).

Possible values are:

- 0 – 1 step – slowest increment
- 1 – 2 steps
- 2 – 4 steps
- 3 – 8 steps – fastest increment

Object Description			
Index	Name	Object Type	Data Type
209B _h	Smart Energy Current Up Step	Variable	UNSIGNED8

Table 118: Object Description (209B_h)

Entry Description				
Sub-index	Access	PDO Mapping	Value Range	Default Value
0	rw	no	0...3	0

Table 119: Entry Description (209B_h)

4.3.45 Object 209C_h: Smart Energy Hysteresis Start

This object serves to set the lower threshold for the stallGuard2 value (see smart Energy current up step (section 4.3.44). Setting this to 0 disables the coolStep function.

Object Description			
Index	Name	Object Type	Data Type
209C _h	Smart Energy Hysteresis Start	Variable	UNSIGNED8

Table 120: Object Description (209C_h)

Entry Description				
Sub-index	Access	PDO Mapping	Value Range	Default Value
0	rw	no	0 .. 15	0

Table 121: Entry Description (209C_h)

4.3.46 Object 209D_h: Smart Energy Filter Enable

This object is used to set the stallGuard2 filter for more precision of the measurement. It reduces the measurement frequency to one measurement per four fullsteps if set.

In most cases it is expedient to set the filtered mode when using coolStep. Use the standard mode for step loss detection.

Possible values are:

- 0 – standard mode
- 1 – filtered mode

Object Description			
Index	Name	Object Type	Data Type
209D _h	Smart Energy Filter Enable	Variable	UNSIGNED8

Table 122: Object Description (209D_h)

Entry Description				
Sub-index	Access	PDO Mapping	Value Range	Default Value
0	rw	no	0/1	0

Table 123: Entry Description (209D_h)

4.3.47 Object 209E_h: stallGuard2 Threshold

This signed value controls the stallGuard2 threshold level for stall output and sets the optimum measurement range for readout. A lower value gives a higher sensitivity. Zero is the starting value. A higher value makes stallGuard2 less sensitive and requires more torque to indicate a stall.

Object Description			
Index	Name	Object Type	Data Type
209E _h	stallGuard2 Threshold	Variable	SIGNED8

Table 124: Object Description (209E_h)

Entry Description				
Sub-index	Access	PDO Mapping	Value Range	Default Value
0	rw	no	-63...63	0

Table 125: Entry Description (209E_h)

4.3.48 Object 209F_h: Slope Control High Side

This value determines the slope of the motor driver outputs. Set to 2 or 3 for this module or better use the default value. (0 for lowest slope, 3 for fastest slope).

Object Description			
Index	Name	Object Type	Data Type
209F _h	Slope control high side	Variable	UNSIGNED8

Table 126: Object Description (209F_h)

Entry Description				
Sub-index	Access	PDO Mapping	Value Range	Default Value
0	rw	no	0...3	3

Table 127: Entry Description (209F_h)

4.3.49 Object 20A0_h: Slope Control Low Side

This value determines the slope of the motor driver outputs. Set to the same value as object 209F_h or use the default value. (0 for lowest slope, 3 for fastest slope).

Object Description			
Index	Name	Object Type	Data Type
20A0 _h	Slope control low side	Variable	UNSIGNED8

Table 128: Object Description (20A0_h)

Entry Description				
Sub-index	Access	PDO Mapping	Value Range	Default Value
0	rw	no	0...3	3

Table 129: Entry Description (20A0_h)

4.3.50 Object 20A1_h: Short Protection Disable

This object is used to enable or to disable the short to ground protection. Normally there is no need to change this. Use the default value.

Possible values are:

- 0 – Short to GND protection enabled
- 1 – Short to GND protection disabled

Object Description			
Index	Name	Object Type	Data Type
20A1 _h	Short Protection Disable	Variable	UNSIGNED8

Table 130: Object Description (20A1_h)

Entry Description				
Sub-index	Access	PDO Mapping	Value Range	Default Value
0	rw	no	0/1	0

Table 131: Entry Description (20A1_h)

4.3.51 Object 20A2_h: Short Detection Timer

This object sets the timeout for the short to ground protection. Normally there is no need to change this. Use the default value. 0 sets the timeout to the longest possible value, and 3 selects the shortest possible value.

Object Description			
Index	Name	Object Type	Data Type
20A2 _h	Short Protection Disable	Variable	UNSIGNED8

Table 132: Object Description (20A2_h)

Entry Description				
Sub-index	Access	PDO Mapping	Value Range	Default Value
0	rw	no	0...3	3

Table 133: Entry Description (20A2_h)

4.3.52 Object 20A3_h: Vsense

This object is used for setting the sense resistor voltage based current scaling. *Use the default value and change only when recommended by Trinamic.*

Possible settings are:



- 0 - Full scale sense resistor voltage is 1/18 VDD
- 1 - Full scale sense resistor voltage is 1/36 VDD

Object Description			
Index	Name	Object Type	Data Type
20A3 _h	Vsense	Variable	UNSIGNED8

Table 134: Object Description (20A3_h)

Entry Description				
Sub-index	Access	PDO Mapping	Value Range	Default Value
0	rw	no	0/1	0

Table 135: Entry Description (20A3_h)

4.3.53 Object 2100_h: Home Offset Display

This object shows the home offset. The value is given in microsteps.

Object Description			
Index	Name	Object Type	Data Type
2100 _h	Home Offset Display	Variable	SIGNED32

Table 136: Object Description (2100_h)

Entry Description				
Sub-index	Access	PDO Mapping	Value Range	Default Value
0	ro	no	-2147483648...2147483647	0

Table 137: Entry Description (2100_h)

4.3.54 Object 2101_h: Actual Load Value

This object shows the home offset. The value is given in microsteps.

Object Description			
Index	Name	Object Type	Data Type
2101 _h	Home Offset Display	Variable	UNSIGNED16

Table 138: Object Description (2101_h)

Entry Description				
Sub-index	Access	PDO Mapping	Value Range	Default Value
0	ro	no	0...1023	0

Table 139: Entry Description (2101_h)

4.3.55 Object 2102_h: Driver Error Flags

This object shows the error flags of the motor driver IC.

Error Flags		
Bit	Name	Meaning
7	OT	Overtemperature
6	OTPW	Temperature pre-warning
5	UV	Undervoltage
4	OCHS	Overcurrent high side
3	OLB	Open load on bridge B
2	OLA	Open load on bridge A
1	OCB	Overcurrent on bridge B
0	OCA	Overcurrent on bridge A

Table 140: Driver Error Flags (2102_h)

Object Description			
Index	Name	Object Type	Data Type
2102 _h	Home Offset Display	Variable	UNSIGNED8

Table 141: Object Description (2102_h)

Entry Description				
Sub-index	Access	PDO Mapping	Value Range	Default Value
0	ro	no	0...255	0

Table 142: Entry Description (2102_h)

4.3.56 Object 2107_h: Microstep resolution display

This object shows the microstep resolution, set by object 2000_h (please see section 4.3.1).



Object Description			
Index	Name	Object Type	Data Type
2107 _h	Microstep resolution display	Variable	UNSIGNED8

Table 143: Object Description (2107_h)

Entry Description				
Sub-index	Access	PDO Mapping	Value Range	Default Value
0	ro	no	0...8	8

Table 144: Entry Description (2107_h)

4.3.57 Object 210B_h: Step Counter

This object shows the overall number of microsteps done by this motor so far. The value can be read as a 64 bit value (sub-index 3) or split into two 32 bit values (sub-index 1 and sub-index 2).

Object Description			
Index	Name	Object Type	Data Type
210B _h	Step Counter	Variable	RECORD

Table 145: Object Description (210B_h)

Entry Description					
Sub-index	Description	Access	PDO Mapping	Value Range	Default Value
1	Lower 32 Bits	ro	no	0... ffffffff _h	0
2	Higher 32 Bits	ro	no	0... ffffffff _h	0
3	64 Bit Value	ro	no	0... ffffffffffffffff _h	0

Table 146: Entry Description (210B_h)

4.3.58 Object 2700_h: TMCL Direct Communication

After writing the make signature 656b616d_h to this object the drive switches to TMCL mode. The drive can then only be controlled via TMCL commands written to the OS command object 1023/01_h. The drive can only be reset to normal CANopen functionality using the DS-301 reset application command.

Object Description			
Index	Name	Object Type	Data Type
2700 _h	TMCL Direct Communication	Variable	UNSIGNED32

Table 147: Object Description (2700_h)



Entry Description				
Sub-index	Access	PDO Mapping	Value Range	Default Value
0	rw	no	656b616d _h	0

Table 148: Entry Description (2700)_h

4.3.59 Object 2701_h: Manufacturer Specific Mode

Writing the make signature to this object turns on the manufacturer specific mode. The manufacturer specific mode can be turned off again by writing the kill signature to this object. The manufacturer specific mode has the following features:

- PDOs do not need to be disabled and re-enabled when the PDO mapping is to be changed.
- The RTR bit in the COB-ID of PDO definitions is ignored.

read:	0	= manufacturer specific mode is inactive
	1	= manufacturer specific mode is active
write:	656b616d _h	= make signature
	6c6c696b _h	= kill signature

Object Description			
Index	Name	Object Type	Data Type
2701 _h	Manufacturer Specific Mode	Variable	UNSIGNED32

Table 149: Object Description (2701)_h

Entry Description				
Sub-index	Access	PDO Mapping	Value Range	Default Value
0	rw	no	see above	0

Table 150: Entry Description (2701)_h

4.3.60 Object 2702_h: Device Digital Inputs

Bits 19...16 of this object reflect the states of the four general purpose inputs of the module.



Bit Definitions	
Bit	Description
16	IN0
17	IN1
18	IN2
19	IN3

Table 151: Bit Definitions (2702_h)

Object Description			
Index	Name	Object Type	Data Type
2702 _h	Device Digital Inputs	Variable	UNSIGNED32

Table 152: Object Description (2702_h)

Entry Description				
Sub-index	Access	PDO Mapping	Value Range	Default Value
0	ro	no	-	0

Table 153: Entry Description (2702_h)

4.3.61 Object 2703_h: Device Digital Outputs

With this object the digital outputs (general purpose outputs) can be set. Bits 19...16 of sub index 1 switch outputs OUT0, OUT1, OUT2 and OUT3 of the module. Bits 19...16 of sub index 2 determine which outputs can be switched. The number of available digital outputs depends on the module type.

Bit Definitions	
Bit	Description
16	OUT0
17	OUT1
18	OUT2
19	OUT3

Table 154: Bit Definitions (2703_h)



Object Description			
Index	Name	Object Type	Data Type
2703 _h	Smart Energy Current Up Step	Variable	ARRAY

Table 155: Object Description (2703_h)

Entry Description					
Sub-index	Description	Access	PDO Mapping	Value Range	Default Value
1	Physical outputs	rw	no	UNSIGNED32	0
2	Output mask	rw	no	UNSIGNED32	0

Table 156: Entry Description (2703_h)

4.3.62 Object 2704_h: CAN Bit Rate

With this object it is possible to change the CAN bit rate. To do this, first write the new value to this object. Then, store the new setting by writing the save signature to object 2706_h. After that, reset the module. The new setting then becomes active.

Object Description			
Index	Name	Object Type	Data Type
2704 _h	CAN Bit Rate	Variable	UNSIGNED16

Table 157: Object Description (2704_h)

Entry Description				
Sub-index	Access	PDO Mapping	Value Range	Default Value
0	rw	no	20,50,100,125,250,500,800,1000	1000

Table 158: Entry Description (2704_h)

How to change the bit rate of a module:

- Write new bit rate in object 2704_h.
- Write the save signature 65766173_h to sub-index 1 of object 2706_h.
- Reset module.

4.3.63 Object 2705_h: Node ID

On modules that do not have address switches the node ID can be selected using this object. On modules with address switches the node ID is normally selected using the address switches. Only when the address switches are set to an invalid value (0 or >127) this object overrides the address switch setting.



To change the node ID, first write the new node ID to this object. Then, store the new setting by writing the save signature to object 2706_h. After that, reset the module. The new setting then becomes active.

Object Description			
Index	Name	Object Type	Data Type
2705 _h	Node ID	Variable	UNSIGNED8

Table 159: Object Description (2705_h)

Entry Description				
Sub-index	Access	PDO Mapping	Value Range	Default Value
0	rw	no	1...127	1

Table 160: Entry Description (2705)_h

How to change the node ID of a module:

- Write new node ID to object 2705_h.
- Write save signature 65766173_h to sub-index 1 of object 2706_h.
- Reset the module.

4.3.64 Object 2706_h: Store

Writing the save signature to this object permanently saves changes made to objects 2704_h and 2705_h. The save signature is 65766173_h.

Object Description			
Index	Name	Object Type	Data Type
2706 _h	Store	Variable	UNSIGNED32

Table 161: Object Description (2706_h)

Entry Description				
Sub-index	Access	PDO Mapping	Value Range	Default Value
0	rw	no	save signature: 65766173 _h	1

Table 162: Entry Description (2706)_h

4.3.65 Object 2707_h: CAN Bit Rate Load

This object shows the selected CAN bit rate.



Object Description			
Index	Name	Object Type	Data Type
2707 _h	CAN Bit Rate Load	Variable	UNSIGNED8

Table 163: Object Description (2707_h)

Entry Description				
Sub-index	Access	PDO Mapping	Value Range	Default Value
0	ro	no	20...1000	depends on bit rate

Table 164: Entry Description (2707_h)

4.3.66 Object 2708_h: Node ID Load

This object shows the selected node ID.

Object Description			
Index	Name	Object Type	Data Type
2708 _h	Node ID Load	Variable	UNSIGNED8

Table 165: Object Description (2708_h)

Entry Description				
Sub-index	Access	PDO Mapping	Value Range	Default Value
0	ro	no	1..127	Depends on node ID setting

Table 166: Entry Description (2708_h)

4.3.67 Object 270E_h: Device Analog Inputs

This object shows the values of the analog inputs of the device.

Object Description			
Index	Name	Object Type	Data Type
270E _h	Device Analog Inputs	Array	UNSIGNED32

Table 167: Object Description (270E_h)



Entry Description					
Sub-index	Description	Access	PDO Mapping	Value Range	Default Value
1	Analog input 0	ro	no	0...4095	–
2	Analog input 1	ro	no	0...4095	–
3	Analog input 2	ro	no	0...4095	–
4	Analog input 3	ro	no	0...4095	–

Table 168: Entry Description (270E_h)



5 Profile specific area

The profile segment contains CiA-402 standard motion control objects. These objects control the motion control functions of the TMCM-1310. Since it is not possible to operate the modes in parallel, the user is able to activate the required function by selecting a mode of operation. The control device writes to the modes of operation object in order to select the operation mode. The drive device provides the modes of operation display object to indicate the actual activated operation mode. Controlword, statusword, and set-points are used mode-specific. This implies the responsibility of the control device to avoid inconsistencies and erroneous behavior.

The following operating modes (selectable via object 6060_h, please see 5.1.6) are implemented on the TMCM-1310:

- Profile position mode (pp)
- Profile velocity mode (pv)
- Homing mode (hm)
- Cyclic position mode (csp)

5.1 Detailed object specifications

5.1.1 Object 605A_h: Quick stop option code

This object indicates what action is performed when the quick stop function is executed. The slow down ramp is the deceleration value of the used mode of operation. The following quick stop option codes are supported in the current version of the CANopen firmware:

Value Definition	
Value	Definition
1	Slow down on <i>slow down ramp</i> and transit into <i>switch on disabled</i>
2	Slow down on <i>quick stop ramp</i> and transit into <i>switch on disabled</i>
5	Slow down on <i>slow down ramp</i> and stay in <i>quick stop active</i>)
6	Slow down on <i>quick stop ramp</i> and stay in <i>quick stop active</i>

Table 169: Value Description (605A_h)

Object Description			
Index	Name	Object Type	Data Type
605A _h	Quick stop option code	Variable	SIGNED16

Table 170: Object Description (605A_h)

Entry Description				
Sub-index	Access	PDO Mapping	Value Range	Default Value
0	rw	no	1/2/5/6	2

Table 171: Entry Description (605A_h)



5.1.2 Object 605B_h: Shutdown option code

This object indicates what action is performed if there is a transition from *operation enabled* state to *ready to switch on state*. The shutdown option code always has the value 0 as only this is supported.

Value Definition	
Value	Definition
0	Disable drive function (switch off the power stage)

Table 172: Value Description (605B_h)

Object Description			
Index	Name	Object Type	Data Type
605B _h	Quick stop option code	Variable	UNSIGNED16

Table 173: Object Description (605B_h)

Entry Description				
Sub-index	Access	PDO Mapping	Value Range	Default Value
0	rw	no	0	0

Table 174: Entry Description (605B_h)

5.1.3 Object 605C_h: Disable operation option code

This object indicates what action is performed if there is a transition from *operation enabled* state to *switched on state*. The disable operation option code always has the value 1 as only this is supported. The slow down ramp is the deceleration value of the used mode of operation.

Value Definition	
Value	Definition
1	Slow down on slow down ramp

Table 175: Value Description (605C_h)

Object Description			
Index	Name	Object Type	Data Type
605C _h	Disable operation option code	Variable	UNSIGNED16

Table 176: Object Description (605C_h)



Entry Description				
Sub-index	Access	PDO Mapping	Value Range	Default Value
0	rw	no	1	1

Table 177: Entry Description (605C_h)

5.1.4 Object 605D_h: Halt option code

This object indicates what action is performed when the halt function is executed. The slow down ramp is the deceleration value of the used mode of operation. The halt option code always has the value 1 as only this is supported.

Value Definition	
Value	Definition
1	Slow down on slow down ramp and stay in <i>operation enabled</i>

Table 178: Value Description (605D_h)

Object Description			
Index	Name	Object Type	Data Type
605D _h	Halt option code	Variable	UNSIGNED16

Table 179: Object Description (605D_h)

Entry Description				
Sub-index	Access	PDO Mapping	Value Range	Default Value
0	rw	no	1	1

Table 180: Entry Description (605D_h)

5.1.5 Object 605E_h: Fault reaction option code

This object indicates what action is performed when fault is detected in the power drive system. The slow down ramp is the deceleration value of the used mode of operation. The fault reaction option code always has the value 2 as only this is supported.

Value Definition	
Value	Definition
2	Slow down on quick stop ramp

Table 181: Value Description (605E_h)

Object Description			
Index	Name	Object Type	Data Type
605E _h	Fault reaction option code	Variable	UNSIGNED16

Table 182: Object Description (605E_h)

Entry Description				
Sub-index	Access	PDO Mapping	Value Range	Default Value
0	rw	no	2	2

Table 183: Entry Description (605E_h)

5.1.6 Object 6060_h: Modes of operation

This object indicates the requested operation mode. Supported operating modes are:

Value Definition	
Value	Mode
0	No mode
1	Profile position mode (pp)
3	Profile velocity mode (pv)
6	Homing mode (hm)
8	Cyclic synchronous position mode (csp)
10	Cyclic synchronous torque mode (cst)

Table 184: Value Description (6060_h)

The motor will not run when the operating mode is set to 0. It will be stopped when the motor is running in one of the supported operating modes and the operating mode is then switched to 0.

Object Description			
Index	Name	Object Type	Data Type
6060 _h	Modes of operation	Variable	SIGNED8

Table 185: Object Description (6060_h)

Entry Description				
Sub-index	Access	PDO Mapping	Value Range	Default Value
0	rw	refer to CiA-402	0/1/3/6	0

Table 186: Entry Description (6060_h)

5.1.7 Object 6061_h: Modes of operation

This object shows the operating mode that is currently set.

Value Definition	
Value	Mode
0	No mode
1	Profile position mode (pp)
3	Profile velocity mode (pv)
6	Homing mode (hm)
8	Cyclic synchronous position mode (csp)
10	Cyclic synchronous torque mode (cst)

Table 187: Value Description (6061_h)

The motor will not run when the operating mode is set to 0. It will be stopped when the motor is running in one of the supported operating modes and the operating mode is then switched to 0.

Object Description			
Index	Name	Object Type	Data Type
6061 _h	Modes of operation display	Variable	SIGNED8

Table 188: Object Description (6061_h)

Entry Description				
Sub-index	Access	PDO Mapping	Value Range	Default Value
0	rw	refer to CiA-402	0/1/3/6	0

Table 189: Entry Description (6061_h)

5.1.8 Object 606A_h: Sensor selection code

This object provides the source of the velocity sensor actual value. It selects whether an encoder is to be used or not.



Value Definition	
Value	Mode
0	Encoder used
-1	No encoder

Table 190: Value Description (606A_h)

Object Description			
Index	Name	Object Type	Data Type
606A _h	Sensor selection code	Variable	SIGNED16

Table 191: Object Description (606A_h)

Entry Description				
Sub-index	Access	PDO Mapping	Value Range	Default Value
0	rw	no	0/-1	-1

Table 192: Entry Description (606A_h)

5.1.9 Object 608F_h: Position Encoder Resolution

This object defines the resolution of the encoder. The position encoder resolution is calculated by the following formula:

$$\text{position encoder resolution} = \frac{\text{encoder increments}}{\text{motor revolutions}}$$

All values are dimensionless.

Object Description			
Index	Name	Object Type	Data Type
608F _h	Position Encoder Resolution	Array	UNSIGNED32

Table 193: Object Description (608F_h)

Entry Description					
Sub-index	Description	Access	PDO Mapping	Value Range	Default Value
0	Highest sub-index supported	ro	no	2	2
1	Encoder increments	rw	no	0...2147483647	1
2	Motor revolutions	ro	no	1	1

Table 194: Entry Description (608F_h)



5.1.10 Object 60FD_h: Digital Inputs

This object contains the states of the digital inputs of the module. Starting from bit 0, every bit reflects the state of one digital input. The number of valid bits depends on the number of digital inputs on the module used.

Object Description			
Index	Name	Object Type	Data Type
60FD _h	Digital inputs	Variable	UNSIGNED32

Table 195: Object Description (60FD_h)

Entry Description				
Sub-index	Access	PDO Mapping	Value Range	Default Value
0	rw	mappable	UNSIGNED32	0

Table 196: Entry Description (60FD_h)

5.1.11 Object 6502_h: Supported Drive Modes

This object provides information on the supported drive modes. A bit that is set means that the mode is supported, a bit that is not set means that the mode is not supported by the drive.

Value Definition	
Bit	Mode
0	Profile position mode (pp)
1	Velocity mode (vl)
2	Profile velocity mode (pv)
3	Torque mode (tq)
4	Reserved
5	Homing mode (hm)
6	Interpolated position mode (ip)
7	Cyclic synchronous position mode (csp)
8	Cyclic synchronous velocity mode (csv)
9	Cyclic synchronous torque mode (cst)

Table 197: Value Definition (6502_h)



Object Description			
Index	Name	Object Type	Data Type
6502 _h	Supported drive modes	Variable	UNSIGNED32

Table 198: Object Description (6502_h)

Entry Description				
Sub-index	Access	PDO Mapping	Value Range	Default Value
0	ro	no	UNSIGNED32	Depends on supported modes.

Table 199: Entry Description (6502_h)



6 Profile position mode

A target position is applied to the trajectory generator. It is generating a position demand value for the position control loop described in the position control function.

Please refer to object 6060_h (section 5.1.6) for information about how to choose an operation mode.

Object 6061_h (section 5.1.7) shows the operation mode that is set.

6.1 Detailed Object Specifications

The following text offers detailed object specifications. For a better understanding, it is necessary to see how the state machine works.

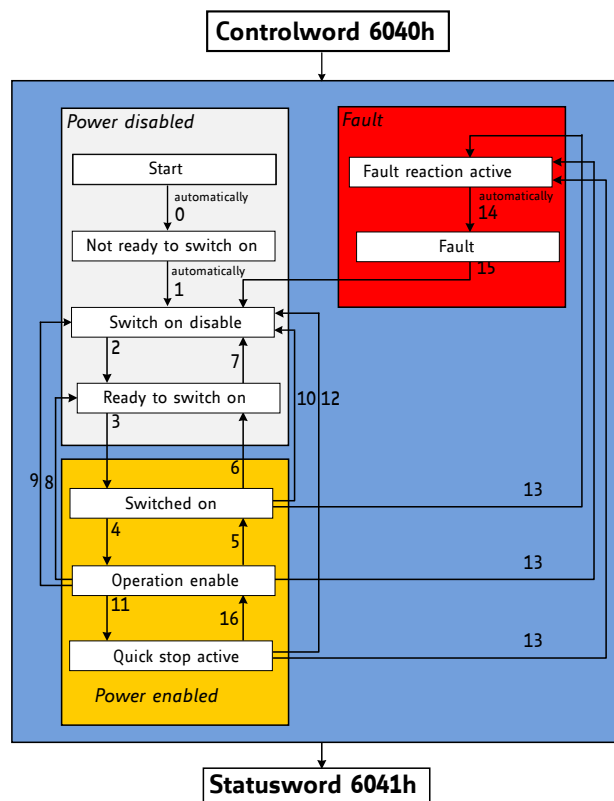

Figure 5: DS402 Finite State Machine

Notes on state transitions:

- Commands directing a change in state are processed completely and the new state achieved before additional state change commands are processed.
- Transitions 0 and 1 occur automatically at drive power-on or reset. Transition 14 occurs automatically, too. All other state changes must be directed by the host.
- Drive function disabled indicates that no current is being supplied to the motor.
- Drive function enabled indicates that current is available for the motor and profile position and profile velocity reference values may be processed.



6.1.1 Object 6040_n: Control Word

This object indicates the received command controlling the power drive system finite state automaton (PDS FSA). The CiA-402 state machine can be controlled using this object. Please refer to figure 5 for detailed information.

Structure of the control word											
15	11	10	9	8	7	6	4	3	2	1	0
nu	r	oms	h	fr	oms	eo	qs	ev	so		
MSB										LSB	

Legend: nu=not used; r=reserved; oms=operation mode specific; h=halt; fr=fault reset; eo=enable operation; qs=quick stop; ev=enable voltage; so=switch on.

Table 200: Structure of the Control Word in pp Mode

Operation mode specific bits in pp mode		
Bit	Name	Definition
4	New set point	0-to-1: the next positioning will be started.
5	Change immediately	Not supported.
6	Absolute / relative	0: New position is absolute. 1: New position is relative.
9	Change set point	Not supported.

Table 201: Operation Mode specific Bits in pp Mode

Command coding						
Command	Bits of control word					Transitions
	Bit 7	Bit 3	Bit 2	Bit 1	Bit 0	
Shutdown	0	x	1	1	0	2,6,8
Switch on	0	0	1	1	1	3
Switch on & enable operation	0	1	1	1	1	3, 4
Disable voltage	0	x	x	0	x	7,9,10,12
Quick stop	0	x	0	1	x	7,10,11
Disable operation	0	0	1	1	1	5
Enable operation	0	1	1	1	1	4, 16
Fault reset	0-to-1	x	x	x	x	15

Table 202: Command Coding



Object Description			
Index	Name	Object Type	Data Type
6040 _h	Controlword	Variable	UNSIGNED16

Table 203: Object Description (6040_h in pp Mode)

Entry Description				
Sub-index	Access	PDO Mapping	Value Range	Default Value
0	rw	see CiA402-3	See command coding above.	

Table 204: Entry Description (6040_h in pp Mode)

6.1.2 Object 6041_h: Status Word

This object provides the status of the PDS FSA. It reflects the status of the CiA-402 state machine. Please refer to figure 5 for detailed information. The object is structured as defined below. For more information about the coding please refer to the CANopen Drives and motion control device profile, part 2.

Structure of the Status Word															
15	14	13	12	11	10	9	8	7	6	5	4	3	2	1	0
dir	mot	oms	ila	tr	rm	ms	w	sod	qs	ve	f	oe	so	rtso	
MSB														LSB	

Legend: nu=not used; r=reserved; oms=operation mode specific; h=halt; fr=fault reset; eo=enable operation; qs=quick stop; ev=enable voltage; so=switch on.

Table 205: Structure of the Status Word in pp Mode

Trinamic Specific Bits		
Bit	Name	Definition
14	Motor activity	0: Motor stands still. 1: Motor rotates.
15	Direction of rotation	This bit shows the direction of rotation.

Table 206: Trinamic Specific Bits



Operation Mode specific Bits in pp Mode		
Bit	Name	Definition
10	Target reached	Set when the motor is within the position window.
12	Set point acknowledged	0: Set point processed. 1: Set point still in process.
13	Following error	Not supported.

Table 207: Operation Mode specific Bits in pp Mode

State Coding	
Status word	FSA state
xxxx xxxx x0xx 0000 _h	Not ready to switch on
xxxx xxxx x1xx 0000 _h	Switch on disabled
xxxx xxxx x01x 0001 _h	Ready to switch on
xxxx xxxx x01x 0011 _h	Switched on
xxxx xxxx x01x 0111 _h	Operation enabled
xxxx xxxx x00x 0111 _h	Quick stop active
xxxx xxxx x0xx 1111 _h	Fault reaction active
xxxx xxxx x0xx 1000 _h	Fault

Table 208: State Coding

Object Description			
Index	Name	Object Type	Data Type
6041 _h	Controlword	Variable	UNSIGNED16

Table 209: Object Description (6041_h in pp Mode)

Entry Description				
Sub-index	Access	PDO Mapping	Value Range	Default Value
0	rw	see CiA402-3	See state coding above.	

Table 210: Entry Description (6041_h in pp Mode)

6.1.3 Object 6062_h: Position Demand Value

This object provides the demanded position value. The value is given in microsteps. Object 6062_h indicates the actual position that the motor should have. It is not to be confused with objects 6063_h and 6064_h.



Object Description			
Index	Name	Object Type	Data Type
6062 _h	Position Demand Value	Variable	SIGNED32

Table 211: Object Description (6062_h)

Entry Description				
Sub-index	Access	PDO Mapping	Value Range	Default Value
0	ro	Refer to CiA402-3	SIGNED32	no

Table 212: Entry Description (6062_h)

6.1.4 Object 6063_h: Position Actual Internal Value

This object provides the actual value of the encoder or the motor. Please use the sensor selection object 606A_h (see section 5.1.8) for selecting the motor or the encoder first. Object 6063_h indicates the actual position of the encoder or the motor, re-scaled to the microstep resolution. The value is given in microsteps.

Object Description			
Index	Name	Object Type	Data Type
6063 _h	Position Actual Internal Value	Variable	SIGNED32

Table 213: Object Description (6063_h)

Entry Description				
Sub-index	Access	PDO Mapping	Value Range	Default Value
0	ro	Refer to CiA402-3	SIGNED32	no

Table 214: Entry Description (6063_h)

6.1.5 Object 6064_h: Position Actual Internal Value

This object provides the actual value of the position measurement device. It always contains the same value as object 6063_h.

Object Description			
Index	Name	Object Type	Data Type
6064 _h	Position Actual Internal Value	Variable	SIGNED32

Table 215: Object Description (6064_h)

Entry Description				
Sub-index	Access	PDO Mapping	Value Range	Default Value
0	ro	Refer to CiA402-3	SIGNED32	no

Table 216: Entry Description (6064_h)

6.1.6 Object 6065_h: Following Error Window

This object indicates the configured range of tolerated position values symmetrically to the position demand value. If the position actual value is out of the following error window, a following error occurs. A following error may occur when a drive is blocked, unreachable profile velocity occurs, or at wrong closed-loop coefficients. The value shall be given in microsteps.

When the difference between motor position (object 6062_h) and encoder position (object 6063_h or 6064_h) is greater than the value set here, the motor will be stopped and an emergency message will be sent. Setting this object to zero will turn off this feature completely.

Note Setting this object to a too low value will lead to false alarms.

Object Description			
Index	Name	Object Type	Data Type
6065 _h	Following Error Window	Variable	UNSIGNED32

Table 217: Object Description (6065_h)

Entry Description				
Sub-index	Access	PDO Mapping	Value Range	Default Value
0	rw	no	0...2147483647	0

Table 218: Entry Description (6065_h)

6.1.7 Object 6067_h: Position Window

This object indicates the configured symmetrical range of accepted positions relative to the target position. If the actual value of the position encoder is within the position window, this target position is regarded as having been reached. The value is given in increments. If the value of the position window is FFFFFFFF_h, the position window control is switched off. If this object is set to zero, the target reached event will be signaled when the demand position (6062_h) has reached the target position (6064_h). When the position window is set to a value greater than zero, the target reached event will be signaled when the actual encoder position value (6064_h) is within $(target_position - position_window)$ and $(target_position + position_window)$.



Object Description			
Index	Name	Object Type	Data Type
6067 _h	Position Window	Variable	UNSIGNED32

Table 219: Object Description (6067_h)

Entry Description				
Sub-index	Access	PDO Mapping	Value Range	Default Value
0	rw	no	UNSIGNED32	FFFFFFF _h

Table 220: Entry Description (6067_h)

6.1.8 Object 6068_h: Position Window Time

This object indicates the configured time, during which the actual position within the position window is measured. The value is given in ms. If this object is set to a value greater than zero and also the position window (6067_h) is set to a value greater than zero the target reached event will not be signaled until the actual position (6064_h) is at least as many milliseconds within the position window as defined by this object.

Object Description			
Index	Name	Object Type	Data Type
6068 _h	Position Window Time	Variable	UNSIGNED16

Table 221: Object Description (6068_h)

Entry Description				
Sub-index	Access	PDO Mapping	Value Range	Default Value
0	rw	no	UNSIGNED16	0

Table 222: Entry Description (6068_h)

6.1.9 Object 606C_h: Velocity Actual Value

This object shows the actual velocity value of the motor. The value is given in internal or user-defined velocity units (depending on object 208C_h, described in section 4.3.33).

Object Description			
Index	Name	Object Type	Data Type
606C _h	Velocity Actual Value	Variable	SIGNED32

Table 223: Object Description (606C_h)

Entry Description				
Sub-index	Access	PDO Mapping	Value Range	Default Value
0	ro	Refer to CiA402-3	SIGNED32	no

Table 224: Entry Description (606C_h)

6.1.10 Object 607A_h: Target Position

The target position is the position that the drive should move to in profile position mode using the current settings of motion control parameters (such as velocity, acceleration, deceleration, motion profile type etc.). The value of this object is interpreted as absolute or relative depending on the abs/rel flag in the controlword. It is given in microsteps.

Object Description			
Index	Name	Object Type	Data Type
607A _h	Target Position	Variable	SIGNED32

Table 225: Object Description (607A_h in pp Mode)

Entry Description				
Sub-index	Access	PDO Mapping	Value Range	Default Value
0	rw	Refer to CiA402-3	SIGNED32	0

Table 226: Entry Description (607A_h in pp Mode)

6.1.11 Object 607D_h: Software Position Limit

This object indicates the configured maximal and minimal software position limits. These parameters define the absolute position limits for the position demand value and the position actual value. Every new target position is checked against these limits. The limit positions are always relative to the machine home position. Before being compared with the target position, they are corrected internally by the home offset as follows:

$$\text{Corrected_min_position_limit} = \text{min_position_limit} - \text{home_offset}$$

$$\text{Corrected_max_position_limit} = \text{max_position_limit} - \text{home_offset}$$

Object Description			
Index	Name	Object Type	Data Type
607D _h	Software Position Limit	Array	SIGNED32

Table 227: Object Description (607D_h)

Entry Description					
Sub-index	Description	Access	PDO Mapping	Value Range	Default Value
1	Minimum Position Limit	rw	no	SIGNED32	-2147483648
2	Maximum Position Limit	rw	no	SIGNED32	2147483647

Table 228: Entry Description (607D_h)

6.1.12 Object 6081_h: Profile Velocity

This object indicates the configured velocity normally attained at the end of the acceleration ramp during a profiled motion and is valid for both directions of motion. The profile velocity is the maximum velocity used when driving to a new position. It is given in internal or user specific units (depending on object 208C_h, section 4.3.33).

Object Description			
Index	Name	Object Type	Data Type
6081 _h	Profile Velocity	Variable	SIGNED32

Table 229: Object Description (6081_h)

Entry Description				
Sub-index	Access	PDO Mapping	Value Range	Default Value
0	rw	no	SIGNED32	0

Table 230: Entry Description (6081_h)

6.1.13 Object 6082_h: End Velocity

This object indicates the configured velocity normally attained at the end of the deceleration ramp during a profiled motion and is valid for both directions of motion. The end velocity is the velocity used when reaching the new position. It is given in internal or user specific units (depending on object 208C_h, section 4.3.33).

Object Description			
Index	Name	Object Type	Data Type
6082 _h	End Velocity	Variable	SIGNED32

Table 231: Object Description (6082_h)

Entry Description				
Sub-index	Access	PDO Mapping	Value Range	Default Value
0	rw	no	SIGNED32	0

Table 232: Entry Description (6082_h)

6.1.14 Object 6083_h: Profile Acceleration

This object indicates the configured acceleration. Object 6083_h sets the maximum acceleration to be used in profile position and profile velocity mode.

The units for object 6083_h can be chosen with object 208E_h, described in section 4.3.34.

In profile velocity mode, this object also sets the deceleration to be used (the deceleration ramp is always the same as the acceleration ramp in pv mode).

Object Description			
Index	Name	Object Type	Data Type
6083 _h	Profile Acceleration	Variable	SIGNED32

Table 233: Object Description (6083_h)

Entry Description				
Sub-index	Access	PDO Mapping	Value Range	Default Value
0	rw	no	SIGNED32	0

Table 234: Entry Description (6083_h)

6.1.15 Object 6084_h: Profile Deceleration

This object indicates the configured deceleration. Object 6084_h sets the maximum deceleration to be used in profile positioning mode.

The units for object 6084_h can be chosen with object 208E_h, described in section 4.3.34.

Object Description			
Index	Name	Object Type	Data Type
6084 _h	Profile Deceleration	Variable	SIGNED32

Table 235: Object Description (6084_h)

Entry Description				
Sub-index	Access	PDO Mapping	Value Range	Default Value
0	rw	no	SIGNED32	0

Table 236: Entry Description (6084_h)

6.1.16 Object 6085_h: Quick Stop Deceleration

This object indicates the configured deceleration used to stop the motor when the quick stop function is activated and the quick stop code object 605A_h is set to 2 (or 6). The value is given in the same unit as profile acceleration object 6083_h.



Object Description			
Index	Name	Object Type	Data Type
6085 _h	Quick stop deceleration	Variable	UNSIGNED32

Table 237: Object Description (6085_h)

Entry Description				
Sub-index	Access	PDO Mapping	Value Range	Default Value
0	rw	no	UNSIGNED32	51200

Table 238: Entry Description (6085_h)

6.1.17 Object 60F2_h: Positioning Option Code

This object indicates the positioning behaviour in profile position mode. Only bits 0 and 1 (relative option) are supported.

Bit Definitions		
Bit 1	Bit 0	Definition
0	0	Positioning moves shall be performed relative to the preceding (internal absolute) target position.
0	1	Positioning moves shall be performed relative to the actual position demand value (object 6063 _h).
1	0	Positioning moves shall be performed relative to the position actual value (object 6064 _h).
1	1	reserved

Table 239: Bit Definitions of Object 60F2_h

Object Description			
Index	Name	Object Type	Data Type
60F2 _h	Positioning option code	Variable	UNSIGNED16

Table 240: Object Description (60F2_h)

Entry Description				
Sub-index	Access	PDO Mapping	Value Range	Default Value
0	rw	no	UNSIGNED16	0

Table 241: Entry Description (60F2_h)



6.2 How to move a Motor in pp Mode

Here is a little example that shows how to get a motor running in pp mode. In this little example we assume that the module has been reset (and then switched to pre-operational or operational) by NMT commands before. Please note that the values are decimal.

- If you do not have any limit switches connected, first disable the limit switch inputs by writing 3 to object 2005_h.
- Select pp mode by writing 1 to object 6060_h.
- Write 6 to object 6040_h to switch to READY_TO_SWITCH_ON state.
- Write 7 to object 6040_h to switch to SWITCHED_ON state.
- Write 15 to object 6040_h to switch to OPERATION_ENABLED state.
- Write the desired target position (e.g. 500000) to object 607A_h.
- Mark the new target position as active by writing 31 to object 6040_h. The motor starts moving now.
- Reset the activation by writing 15 to object 6040_h (this can be done while the motor is still moving).



7 Profile velocity mode

The profile velocity mode is used to control the velocity of the drive without a special regard of the position. It contains limit functions and trajectory generation.

The profile velocity mode covers the following sub-functions:

- Demand value input via trajectory generator.
- Monitoring of the profile velocity using a window-function.
- Monitoring of velocity actual value using a threshold.

The operation of the reference value generator and its input parameters include:

- Profile velocity
- Profile acceleration
- Profile deceleration
- Emergency stop
- Motion profile type

7.1 Detailed Object Specifications

7.1.1 Object 6040_n: Control Word

This object indicates the received command controlling the power drive system finite state automaton (PDS FSA). The CiA-402 state machine can be controlled using this object. Please refer to figure 5 for detailed information.

In pv mode the control word does not contain any operation mode specific bits.

Structure of the control word											
15	11	10	9	8	7	6	4	3	2	1	0
nu	r	r	h	fr	r	eo	qs	ev	so		
MSB						LSB					

Legend: nu=not used; r=reserved; h=halt; fr=fault reset; eo=enable operation; qs=quick stop; ev=enable voltage; so=switch on.

Table 242: Structure of the Control Word in pv Mode



Command coding						
Command	Bits of control word					Transitions
	Bit 7	Bit 3	Bit 2	Bit 1	Bit 0	
Shutdown	0	x	1	1	0	2,6,8
Switch on	0	0	1	1	1	3
Switch on & enable operation	0	1	1	1	1	3, 4
Disable voltage	0	x	x	0	x	7,9,10,12
Quick stop	0	x	0	1	x	7,10,11
Disable operation	0	0	1	1	1	5
Enable operation	0	1	1	1	1	4, 16
Fault reset	0-to-1	x	x	x	x	15

Table 243: Command Coding

Object Description			
Index	Name	Object Type	Data Type
6040 _h	Controlword	Variable	UNSIGNED16

Table 244: Object Description (6040_h in pv Mode)

Entry Description				
Sub-index	Access	PDO Mapping	Value Range	Default Value
0	rw	see CiA402-3	See command coding above.	

Table 245: Entry Description (6040_h in pv Mode)

7.1.2 Object 6041_h: Status Word

This object provides the status of the PDS FSA. It reflects the status of the CiA-402 state machine. Please refer to figure 5 for detailed information. The object is structured as defined below. For more information about the coding please refer to the CANopen Drives and motion control device profile, part 2.

Structure of the Status Word															
15	14	13	12	11	10	9	8	7	6	5	4	3	2	1	0
dir	mot	oms	ila	tr	rm	ms	w	sod	qs	ve	f	oe	so	rtso	
MSB														LSB	

Legend: nu=not used; r=reserved; oms=operation mode specific; h=halt; fr=fault reset; eo=enable operation; qs=quick stop; ev=enable voltage; so=switch on.

Table 246: Structure of the Status Word in pv Mode



Trinamic Specific Bits		
Bit	Name	Definition
14	Motor activity	0: Motor stands still. 1: Motor rotates.
15	Direction of rotation	This bit shows the direction of rotation.

Table 247: Trinamic Specific Bits

Operation Mode specific Bits in pv Mode		
Bit	Name	Definition
10	Target reached	Indicates that the target speed has been reached.
12	Speed	Not supported.
13	Max. slippage error	Not supported.

Table 248: Operation Mode specific Bits in pv Mode

State Coding	
Status word	FSA state
xxxx xxxx x0xx 0000 _h	Not ready to switch on
xxxx xxxx x1xx 0000 _h	Switch on disabled
xxxx xxxx x01x 0001 _h	Ready to switch on
xxxx xxxx x01x 0011 _h	Switched on
xxxx xxxx x01x 0111 _h	Operation enabled
xxxx xxxx x00x 0111 _h	Quick stop active
xxxx xxxx x0xx 1111 _h	Fault reaction active
xxxx xxxx x0xx 1000 _h	Fault

Table 249: State Coding

Object Description			
Index	Name	Object Type	Data Type
6041 _h	Controlword	Variable	UNSIGNED16

Table 250: Object Description (6041_h in pv Mode)

Entry Description				
Sub-index	Access	PDO Mapping	Value Range	Default Value
0	rw	see CiA402-3	See state coding above	

Table 251: Entry Description (6041_h in pv Mode)

7.1.3 Object 6062_h: Position Demand Value

This object provides the demanded position value. The value is given in microsteps. Object 6062_h indicates the actual position that the motor should have. It is not to be confused with objects 6063_h and 6064_h.

Object Description			
Index	Name	Object Type	Data Type
6062 _h	Position Demand Value	Variable	SIGNED32

Table 252: Object Description (6062_h)

Entry Description				
Sub-index	Access	PDO Mapping	Value Range	Default Value
0	ro	Refer to CiA402-3	SIGNED32	no

Table 253: Entry Description (6062_h)

7.1.4 Object 6063_h: Position Actual Internal Value

This object provides the actual value of the encoder or the motor. Please use the sensor selection object 606A_h (see section 5.1.8) for selecting the motor or the encoder first. Object 6063_h indicates the actual position of the encoder or the motor, re-scaled to the microstep resolution. The value is given in microsteps.

Object Description			
Index	Name	Object Type	Data Type
6063 _h	Position Actual Internal Value	Variable	SIGNED32

Table 254: Object Description (6063_h)

Entry Description				
Sub-index	Access	PDO Mapping	Value Range	Default Value
0	ro	Refer to CiA402-3	SIGNED32	no

Table 255: Entry Description (6063_h)



7.1.5 Object 6064_h: Position Actual Internal Value

This object provides the actual value of the position measurement device. It always contains the same value as object 6063_h.

Object Description			
Index	Name	Object Type	Data Type
6064 _h	Position Actual Internal Value	Variable	SIGNED32

Table 256: Object Description (6064_h)

Entry Description				
Sub-index	Access	PDO Mapping	Value Range	Default Value
0	ro	Refer to CiA402-3	SIGNED32	no

Table 257: Entry Description (6064_h)

7.1.6 Object 6065_h: Following Error Window

This object indicates the configured range of tolerated position values symmetrically to the position demand value. If the position actual value is out of the following error window, a following error occurs. A following error may occur when a drive is blocked, unreachable profile velocity occurs, or at wrong closed-loop coefficients. The value shall be given in microsteps.

When the difference between motor position (object 6062_h) and encoder position (object 6063_h or 6064_h) is greater than the value set here, the motor will be stopped and an emergency message will be sent. Setting this object to zero will turn off this feature completely.

Note Setting this object to a too low value will lead to false alarms.

Object Description			
Index	Name	Object Type	Data Type
6065 _h	Following Error Window	Variable	UNSIGNED32

Table 258: Object Description (6065_h)

Entry Description				
Sub-index	Access	PDO Mapping	Value Range	Default Value
0	rw	no	0...2147483647	0

Table 259: Entry Description (6065_h)



7.1.7 Object 606C_h: Velocity Actual Value

This object shows the actual velocity value of the motor. The value is given in internal or user-defined velocity units (depending on object 208C_h, described in section 4.3.33).

Object Description			
Index	Name	Object Type	Data Type
606C _h	Velocity Actual Value	Variable	SIGNED32

Table 260: Object Description (606C_h)

Entry Description				
Sub-index	Access	PDO Mapping	Value Range	Default Value
0	ro	Refer to CiA402-3	SIGNED32	no

Table 261: Entry Description (606C_h)

7.1.8 Object 607D_h: Software Position Limit

This object indicates the configured maximal and minimal software position limits. These parameters define the absolute position limits for the position demand value and the position actual value. Every new target position is checked against these limits. The limit positions are always relative to the machine home position. Before being compared with the target position, they are corrected internally by the home offset as follows:

$$\begin{aligned} \text{Corrected_min_position_limit} &= \text{min_position_limit} - \text{home_offset} \\ \text{Corrected_max_position_limit} &= \text{max_position_limit} - \text{home_offset} \end{aligned}$$

Object Description			
Index	Name	Object Type	Data Type
607D _h	Software Position Limit	Array	SIGNED32

Table 262: Object Description (607D_h)

Entry Description					
Sub-index	Description	Access	PDO Mapping	Value Range	Default Value
1	Minimum Position Limit	rw	no	SIGNED32	-2147483648
2	Maximum Position Limit	rw	no	SIGNED32	2147483647

Table 263: Entry Description (607D_h)



7.1.9 Object 6083_h: Profile Acceleration

This object indicates the configured acceleration. Object 6083_h sets the maximum acceleration to be used in profile position and profile velocity mode.

The units for object 6083_h can be chosen with object 208E_h, described in section 4.3.34.

In profile velocity mode, this object also sets the deceleration to be used (the deceleration ramp is always the same as the acceleration ramp in pv mode).

Object Description			
Index	Name	Object Type	Data Type
6083 _h	Profile Acceleration	Variable	SIGNED32

Table 264: Object Description (6083_h)

Entry Description				
Sub-index	Access	PDO Mapping	Value Range	Default Value
0	rw	no	SIGNED32	0

Table 265: Entry Description (6083_h)

7.1.10 Object 6085_h: Quick Stop Deceleration

This object indicates the configured deceleration used to stop the motor when the quick stop function is activated and the quick stop code object 605A_h is set to 2 (or 6). The value is given in the same unit as profile acceleration object 6083_h.

Object Description			
Index	Name	Object Type	Data Type
6085 _h	Quick stop deceleration	Variable	UNSIGNED32

Table 266: Object Description (6085_h)

Entry Description				
Sub-index	Access	PDO Mapping	Value Range	Default Value
0	rw	no	UNSIGNED32	51200

Table 267: Entry Description (6085_h)

7.1.11 Object 60FF_h: Target Velocity

This object indicates the configured target velocity and is used as input for the trajectory generator. Object 60FF_h sets the target velocity when using profile velocity mode. The drive then accelerates or decelerates to that velocity using the acceleration and deceleration set by objects 6083_h and 6084_h. The values are given in units which can be selected with object 208C_h, described in section 4.3.33.



Object Description			
Index	Name	Object Type	Data Type
60FF _h	Target Velocity	Variable	SIGNED32

Table 268: Object Description (60FF_h)

Entry Description				
Sub-index	Access	PDO Mapping	Value Range	Default Value
0	rw	see CiA402-3	SIGNED32	0

Table 269: Entry Description (60FF_h)

7.2 How to move a Motor in pv Mode

Here is a little example that shows how to get a motor running in pv mode. In this little example we assume that the module has been reset (and then switched to pre-operational or operational) by NMT commands before.

- If you do not have any limit switches connected, first disable the limit switch inputs by writing 3 to object 2005_h.
- Select pv mode by writing 3 to object 6060_h.
- Write 6 to object 6040_h to switch to READY_TO_SWITCH_ON state.
- Write 7 to object 6040_h to switch to SWITCHED_ON state.
- Write 15 to object 6040_h to switch to OPERATION_ENABLED state.
- Write the desired target speed (e.g. 100000) to object 60FF_h. The motor now accelerates to that speed.
- Stop the motor by writing 0 to object 60FF_h.



8 Homing mode

This chapter describes the method by which a drive seeks the home position (reference point). There are various methods of achieving this using limit switches at the ends of travel or a home switch in mid-travel. Some methods also use the index (zero) pulse train from an incremental encoder. The user may specify the speeds, acceleration and the method of homing.

There is no output data except for those bits in the statusword which return the status or result of the homing process and the demand to the position control loops.

There are four sources of the homing signal available: these are positive and negative limit switches, the home switch and the index pulse from an encoder.

Figure 6 shows the defined input objects as well as the output objects. The user can specify the speeds, acceleration and method of homing. The home offset object 607C_h allows displacing the zero in point the coordinate system for the home position.

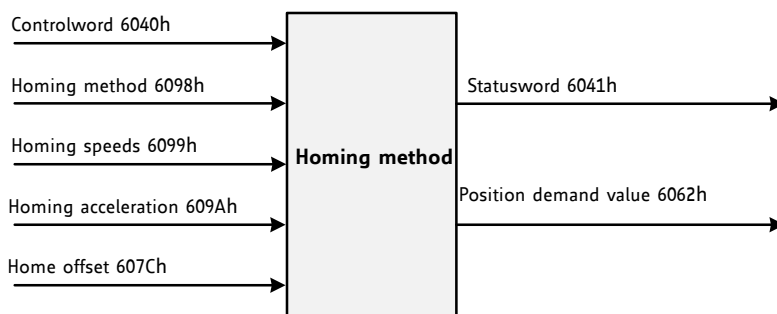

Figure 6: Homing Mode Function

Choosing a homing mode determines the following things:

- The homing signal (positive limit switch, negative limit switch, and home switch).
- The direction of actuation where appropriate.
- The position of the index pulse.

The home position and the zero position are offset by the home offset (see object 607C_h, section 8.2.4).

There are four sources of homing signals available:

- Negative and positive limit switches.
- Home switch.
- Index pulse of an encoder.

For the operation of positioning drives, an exact knowledge of the absolute position is normally required. Since for cost reasons drives often do not have an absolute encoder, a homing operation is necessary.

8.1 Homing Methods

The TMCM-1310 supports a subset of different standard CANopen homing methods. The homing method that is to be used can be chosen via object 6098_h (section 8.2.5).



Supported Homing Methods	
Method	Description
0	No homing (default value for object 6098 _h).
1	Search the left end switch, then search the next encoder index pulse.
2	Search the right end switch, then search the next encoder index pulse.
3	Search the positive edge of the home switch, then search the next encoder index pulse.
5	Search the negative edge of the home switch, then search the next encoder index pulse.
17	Search the left end switch.
18	Search the right end switch.
19	Search the positive edge of the home switch.
21	Search the negative edge of the home switch.
33	Search next index pulse in negative direction.
34	Search next index pulse in positive direction.
35	The actual position is used as home position. All position values (objects 6062 _h , 6063 _h , and 6064 _h) are set to zero, but the motor will not move.

Table 270: Supported CANopen Homing Methods

When using homing methods that need end switch inputs or home switch inputs please take care of their configuration (object 2005_h, section 4.3.6).

8.1.1 Homing Method 1: Homing on negative Limit Switch and Index Pulse

Using this method, the initial direction of movement shall be leftward if the negative limit switch is inactive (here: low). The home position shall be at the first index pulse to the right of the position where the negative limit switch becomes inactive.

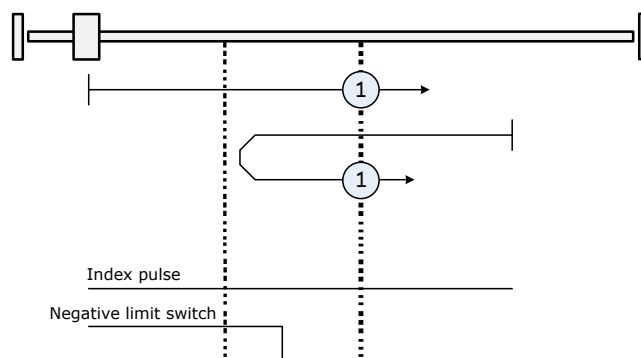

Figure 7: Homing Method 1

8.1.2 Homing Method 2: Homing on positive Limit Switch and Index Pulse

Using this method, the initial direction of movement shall be rightward if the positive limit switch is inactive (here: low). The position of home shall be at the first index pulse to the left of the position where the positive limit switch becomes inactive.



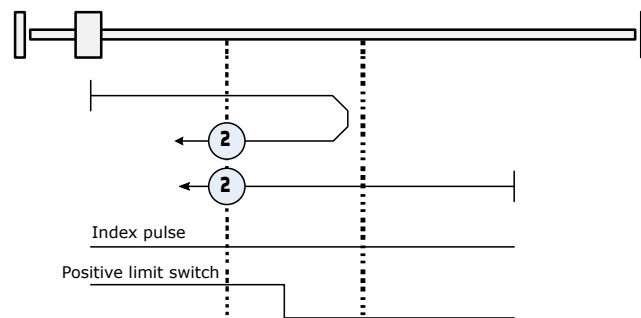

Figure 8: Homing Method 2

8.1.3 Homing Method 3: Homing on positive Home Switch and Index Pulse

Using this method, the initial direction of movement shall be dependent on the state of the home switch. The home position shall be at the index pulse to either to the left or the right of the point where the home switch changes state. If the initial position is situated so that the direction of movement shall reverse during homing, the point at which the reversal takes place is anywhere after a change of state of the home switch.

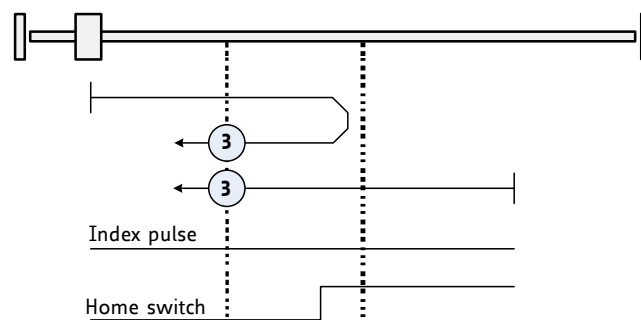

Figure 9: Homing Method 3

8.1.4 Homing Method 5: Homing on negative Home Switch and Index Pulse

Using this method, the initial direction of movement shall be dependent on the state of the home switch. The home position shall be at the index pulse to either to the left or the right of the point where the home switch changes state. If the initial position is situated so that the direction of movement shall reverse during homing, the point at which the reversal takes place is anywhere after a change of state of the home switch.



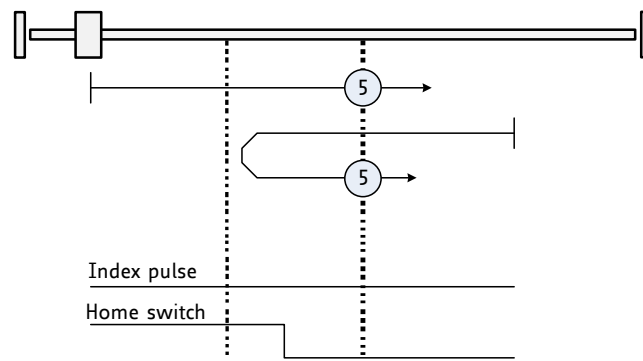

Figure 10: Homing Method 5

8.1.5 Homing Method 17, 18, 19, and 21: Homing without Index Pulse

These methods are similar to methods 1 to 5 except that the home position is not dependent on the index pulse but only dependent on the relevant home or limit switch transitions. As an example, homing method 19 (which is similar to homing method 3) is shown in figure 11.

Homing Methods 17... 21	
Method	Description
17	Search the left end switch. (Similar to method 1)
18	Search the right end switch. (Similar to method 2)
19	Search the positive edge of the home switch. (Similar to method 3)
21	Search the negative edge of the home switch. (Similar to method 5.)

Table 271: Homing Methods 17 - 21

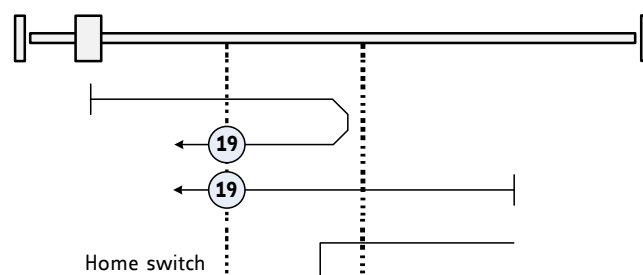

Figure 11: Homing Method 19

8.1.6 Homing Method 33 and 34: Homing on next Index Pulse

Using these methods, the direction of homing is negative or positive respectively. The home position shall be at the index pulse found in the selected direction as shown in Figure 4.10.



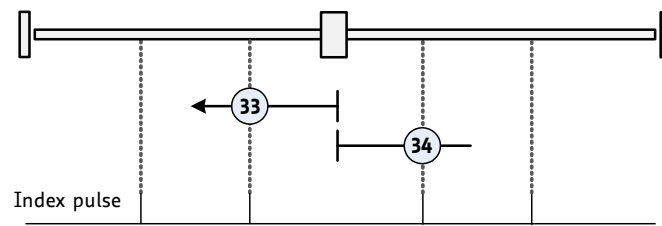

Figure 12: Homing Methods 33 and 34

8.1.7 Homing Method 35: Current position as home position

In this method, the current position shall be taken to be the home position. This method does not require the drive device to be in operation enabled state.



8.2 Detailed Object Specifications

8.2.1 Object 6040_h: Control Word

This object indicates the received command controlling the power drive system finite state automaton (PDS FSA). The CiA-402 state machine can be controlled using this object. Please refer to figure 5 for detailed information.

Structure of the control word												
15	11	10	9	8	7	6	4	3	2	1	0	
nu		r	oms		h	fr	oms		eo	qs	ev	so
MSB											LSB	

Legend: nu=not used; r=reserved; oms=operation mode specific; h=halt; fr=fault reset; eo=enable operation; qs=quick stop; ev=enable voltage; so=switch on.

Table 272: Structure of the Control Word in hm Mode

Operation mode specific bits in hm mode		
Bit	Name	Definition
4	Homing operation start	1: start homing; 0: stop homing
8	Halt	Not supported.

Table 273: Operation Mode specific Bits in hm Mode

Command coding						
Command	Bits of control word					Transitions
	Bit 7	Bit 3	Bit 2	Bit 1	Bit 0	
Shutdown	0	x	1	1	0	2,6,8
Switch on	0	0	1	1	1	3
Switch on & enable operation	0	1	1	1	1	3, 4
Disable voltage	0	x	x	0	x	7,9,10,12
Quick stop	0	x	0	1	x	7,10,11
Disable operation	0	0	1	1	1	5
Enable operation	0	1	1	1	1	4, 16
Fault reset	0-to-1	x	x	x	x	15

Table 274: Command Coding



Object Description			
Index	Name	Object Type	Data Type
6040 _h	Controlword	Variable	UNSIGNED16

Table 275: Object Description (6040_h in hm Mode)

Entry Description				
Sub-index	Access	PDO Mapping	Value Range	Default Value
0	rw	see CiA402-3	See command coding above.	

Table 276: Entry Description (6040_h in hm Mode)

8.2.2 Object 6041_h: Status Word

This object provides the status of the PDS FSA. It reflects the status of the CiA-402 state machine. Please refer to figure 5 for detailed information. The object is structured as defined below. For more information about the coding please refer to the CANopen Drives and motion control device profile, part 2.

Structure of the Status Word															
15	14	13	12	11	10	9	8	7	6	5	4	3	2	1	0
dir	mot	oms	ila	tr	rm	ms	w	sod	qs	ve	f	oe	so	rtso	
MSB														LSB	

Legend: nu=not used; r=reserved; oms=operation mode specific; h=halt; fr=fault reset; eo=enable operation; qs=quick stop; ev=enable voltage; so=switch on.

Table 277: Structure of the Status Word in hm Mode

Trinamic Specific Bits		
Bit	Name	Definition
14	Motor activity	0: Motor stands still. 1: Motor rotates.
15	Direction of rotation	This bit shows the direction of rotation.

Table 278: Trinamic Specific Bits



Operation Mode specific Bits in hm Mode		
Bit	Name	Definition
10	Target reached	Set when the zero position has been found or homing has been stopped by setting controlword bit 4 to zero.
12	Home attained	Set when zero position has been found.
13	Homing error	Not supported.

Table 279: Operation Mode specific Bits in hm Mode

State Coding	
Status word	FSA state
xxxx xxxx x0xx 0000 _h	Not ready to switch on
xxxx xxxx x1xx 0000 _h	Switch on disabled
xxxx xxxx x01x 0001 _h	Ready to switch on
xxxx xxxx x01x 0011 _h	Switched on
xxxx xxxx x01x 0111 _h	Operation enabled
xxxx xxxx x00x 0111 _h	Quick stop active
xxxx xxxx x0xx 1111 _h	Fault reaction active
xxxx xxxx x0xx 1000 _h	Fault

Table 280: State Coding

Object Description			
Index	Name	Object Type	Data Type
6041 _h	Controlword	Variable	UNSIGNED16

Table 281: Object Description (6041_h in hm Mode)

Entry Description				
Sub-index	Access	PDO Mapping	Value Range	Default Value
0	rw	see CiA402-3	See state coding above.	

Table 282: Entry Description (6041_h in hm Mode)

8.2.3 Object 606C_h: Velocity Actual Value

This object shows the actual velocity value of the motor. The value is given in internal or user-defined velocity units (depending on object 208C_h, described in section 4.3.33).



Object Description			
Index	Name	Object Type	Data Type
606C _h	Velocity Actual Value	Variable	SIGNED32

Table 283: Object Description (606C_h)

Entry Description				
Sub-index	Access	PDO Mapping	Value Range	Default Value
0	ro	Refer to CiA402-3	SIGNED32	no

Table 284: Entry Description (606C_h)

8.2.4 Object 607C_h: Home Offset

This object indicates the configured difference between the zero position for the application and the machine home position/home switch (found during homing). While homing, the machine home position is found and once the homing is completed, the zero position is offset from the home position by adding the home offset to the home position. The effect of setting the home position to a non-zero value depends on the selected homing method. The value of this object is given in microsteps. Negative values indicate the opposite direction.

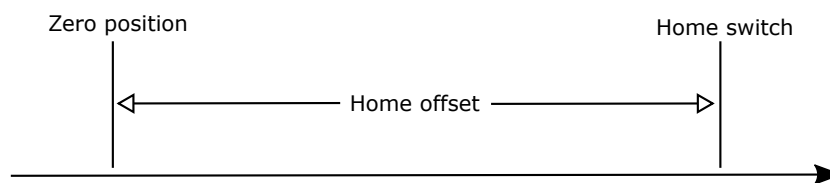

Figure 13: Home Offset

Object Description			
Index	Name	Object Type	Data Type
607C _h	Home offset	Variable	SIGNED32

Table 285: Object Description (607C_h)

Entry Description				
Sub-index	Access	PDO Mapping	Value Range	Default Value
0	rw	no	SIGNED32	0

Table 286: Entry Description (607C_h)

8.2.5 Object 6098_h: Homing Method

The homing method to be used can be selected by writing to this object. Please see table 270 for a list of homing methods supported by the current version of the TMCM-1310 CANopen firmware.

Object Description			
Index	Name	Object Type	Data Type
6098 _h	Homing method	Variable	SIGNED8

Table 287: Object Description (6098_h)

Entry Description				
Sub-index	Access	PDO Mapping	Value Range	Default Value
0	rw	no	SIGNED8	0

Table 288: Entry Description (6098_h)

8.2.6 Object 6099_h: Homing Speeds

This object indicates the configured speeds used during homing procedure. The values are given in pps units or inernal units selectable with object 208C_h (section 4.3.33). Using object 6099_h a fast and a slow homing speed can be set. In most homing modes, the home switch is searched with the fast speed first. When the home switch has been found, the motor will be decelerated to the slow speed (using the homing acceleration, object 609A_h) to search for the exact switch point. When the switch point has been found the motor will be stopped at that point.

Object Description			
Index	Name	Object Type	Data Type
6099 _h	Homing speeds	Array	UNSIGNED32

Table 289: Object Description (6099_h)

Entry Description					
Sub-index	Description	Access	PDO Mapping	Value Range	Default Value
1	Fast homing speed	rw	no	UNSIGNED32	0
2	Slow homing speed	rw	no	UNSIGNED32	0

Table 290: Entry Description (6099_h)

8.2.7 Object 609A_h: Homing Acceleration

This object indicates the configured acceleration and deceleration to be used during homing operation. The value set here will be used for acceleration and for deceleration during homing. The value is given in



units selected by object 208E_h (section 4.3.34).

Object Description			
Index	Name	Object Type	Data Type
609A _h	Homing acceleration	Variable	UNSIGNED32

Table 291: Object Description (609A_h)

Entry Description				
Sub-index	Access	PDO Mapping	Value Range	Default Value
0	rw	no	UNSIGNED32	0

Table 292: Entry Description (609A_h)

8.2.8 Object 2100_h: Home Offset Display

This object shows the home offset. The value is given in microsteps.

Object Description			
Index	Name	Object Type	Data Type
2100 _h	Home Offset Display	Variable	SIGNED32

Table 293: Object Description (2100_h)

Entry Description				
Sub-index	Access	PDO Mapping	Value Range	Default Value
0	ro	no	-2147483648...2147483647	0

Table 294: Entry Description (2100_h)

8.3 How to start a Homing in hm Mode

Here is a little example that shows how to home the motor in hm mode. In this little example we assume that the module has been reset (and then switched to pre-operational or operational) by NMT commands before. The home switch must be connected to the home switch input. It can be operated manually.

- Select hm mode by writing 6 to object 6060_h.
- Write 6 to object 6040_h to switch to READY_TO_SWITCH_ON state.
- Write 7 to object 6040_h to switch to SWITCHED_ON state.
- Write 15 to object 6040_h to switch to OPERATION_ENABLED state.



- Select homing method 19 by writing 19 to object 6098_h.
- Set the homing speeds by writing e.g. 50000 to object 6099_h sub index 1 and e.g. 10000 to object 6099_h sub index 2.
- Write 31 to object 6040_h to start the homing process.
- Press and release the home switch.
- When homing has finished, write 15 to object 6040_h again.



9 Cyclic synchronous Position Mode

The cyclic synchronous position mode is used to directly control the position of the motor. It contains limit functions, but not a trajectory generator. The trajectory generator is located in the control device (the master), not in the drive device. In cyclic synchronous manner, the control device provides a target position to the drive device, which performs position control, velocity control and torque control.

The main control parameters are the target position (object 607A_h, see section 9.1.7) and the interpolation time period (object 60C2_h, see section 9.1.10). The drive automatically sets the velocity in such a manner that the next target position is reached within the interpolation time period. Acceleration and deceleration ramps are not used in this mode.

The cyclic synchronous position mode covers the following sub-functions:

- Position demand value input directly via an object.
- Monitoring of the position.
- Limiting the position using the software limits or the hardware limit switches.

9.1 Detailed Object Specifications

9.1.1 Object 6040_h: Control Word

This object indicates the received command controlling the power drive system finite state automaton (PDS FSA). The CiA-402 state machine can be controlled using this object. Please refer to figure 5 for detailed information. The cyclic synchronous position mode does not use any mode specific bits of the control word.

Structure of the control word									
15	9	8	7	6	4	3	2	1	0
nu		h	fr		nu	eo	qs	ev	so
MSB									LSB

Legend: nu=not used; h=halt; fr=fault reset; eo=enable operation; qs=quick stop; ev=enable voltage; so=switch on.

Table 295: Structure of the Control Word in csp Mode



Command coding						
Command	Bits of control word					Transitions
	Bit 7	Bit 3	Bit 2	Bit 1	Bit 0	
Shutdown	0	x	1	1	0	2,6,8
Switch on	0	0	1	1	1	3
Switch on & enable operation	0	1	1	1	1	3, 4
Disable voltage	0	x	x	0	x	7,9,10,12
Quick stop	0	x	0	1	x	7,10,11
Disable operation	0	0	1	1	1	5
Enable operation	0	1	1	1	1	4, 16
Fault reset	0-to-1	x	x	x	x	15

Table 296: Command Coding

Object Description			
Index	Name	Object Type	Data Type
6040 _h	Controlword	Variable	UNSIGNED16

Table 297: Object Description (6040_h in csp Mode)

Entry Description				
Sub-index	Access	PDO Mapping	Value Range	Default Value
0	rw	see CiA402-3	See command coding above.	

Table 298: Entry Description (6040_h in csp Mode)

9.1.2 Object 6041_h: Status Word

This object provides the status of the PDS FSA. It reflects the status of the CiA-402 state machine. Please refer to figure 5 for detailed information. The object is structured as defined below. For more information about the coding please refer to the CANopen Drives and motion control device profile, part 2.

Structure of the Status Word															
15	14	13	12	11	10	9	8	7	6	5	4	3	2	1	0
dir	mot	oms	ila	r	rm	ms	w	sod	qs	ve	f	oe	so	rtso	
MSB														LSB	

Legend: nu=not used; r=reserved; oms=operation mode specific; h=halt; fr=fault reset; eo=enable operation; qs=quick stop; ev=enable voltage; so=switch on.

Table 299: Structure of the Status Word in csp Mode



Trinamic Specific Bits		
Bit	Name	Definition
14	Motor activity	0: Motor stands still. 1: Motor rotates.
15	Direction of rotation	This bit shows the direction of rotation.

Table 300: Trinamic Specific Bits

Operation Mode specific Bits in csp Mode		
Bit	Name	Definition
10	Reserved	Not used.
12	Target position ignored	0: Target position ignored. 1: Target position used as input to position controller.
13	Following error	0: No following error. 1: Following error.

Table 301: Operation Mode specific Bits in csp Mode

State Coding	
Status word	FSA state
xxxx xxxx x0xx 0000 _h	Not ready to switch on
xxxx xxxx x1xx 0000 _h	Switch on disabled
xxxx xxxx x01x 0001 _h	Ready to switch on
xxxx xxxx x01x 0011 _h	Switched on
xxxx xxxx x01x 0111 _h	Operation enabled
xxxx xxxx x00x 0111 _h	Quick stop active
xxxx xxxx x0xx 1111 _h	Fault reaction active
xxxx xxxx x0xx 1000 _h	Fault

Table 302: State Coding

Object Description			
Index	Name	Object Type	Data Type
6041 _h	Controlword	Variable	UNSIGNED16

Table 303: Object Description (6041_h in csp Mode)



Entry Description				
Sub-index	Access	PDO Mapping	Value Range	Default Value
0	rw	see CiA402-3	See state coding above	

Table 304: Entry Description (6041_h in csp Mode)

9.1.3 Object 6062_h: Position Demand Value

This object provides the demanded position value. The value is given in microsteps. Object 6062_h indicates the actual position that the motor should have. It is not to be confused with objects 6063_h and 6064_h.

Object Description			
Index	Name	Object Type	Data Type
6062 _h	Position Demand Value	Variable	SIGNED32

Table 305: Object Description (6062_h)

Entry Description				
Sub-index	Access	PDO Mapping	Value Range	Default Value
0	ro	Refer to CiA402-3	SIGNED32	no

Table 306: Entry Description (6062_h)

9.1.4 Object 6063_h: Position Actual Internal Value

This object provides the actual value of the encoder or the motor. Please use the sensor selection object 606A_h (see section 5.1.8) for selecting the motor or the encoder first. Object 6063_h indicates the actual position of the encoder or the motor, re-scaled to the microstep resolution. The value is given in microsteps.

Object Description			
Index	Name	Object Type	Data Type
6063 _h	Position Actual Internal Value	Variable	SIGNED32

Table 307: Object Description (6063_h)

Entry Description				
Sub-index	Access	PDO Mapping	Value Range	Default Value
0	ro	Refer to CiA402-3	SIGNED32	no

Table 308: Entry Description (6063_h)



9.1.5 Object 6064_h: Position Actual Internal Value

This object provides the actual value of the position measurement device. It always contains the same value as object 6063_h.

Object Description			
Index	Name	Object Type	Data Type
6064 _h	Position Actual Internal Value	Variable	SIGNED32

Table 309: Object Description (6064_h)

Entry Description				
Sub-index	Access	PDO Mapping	Value Range	Default Value
0	ro	Refer to CiA402-3	SIGNED32	no

Table 310: Entry Description (6064_h)

9.1.6 Object 606C_h: Velocity Actual Value

This object shows the actual velocity value of the motor. The value is given in internal or user-defined velocity units (depending on object 208C_h, described in section 4.3.33).

Object Description			
Index	Name	Object Type	Data Type
606C _h	Velocity Actual Value	Variable	SIGNED32

Table 311: Object Description (606C_h)

Entry Description				
Sub-index	Access	PDO Mapping	Value Range	Default Value
0	ro	Refer to CiA402-3	SIGNED32	no

Table 312: Entry Description (606C_h)

9.1.7 Object 607A_h: Target Position

The target position is the position that the drive should move to in cyclic synchronous position mode using the current interpolation time period. In csp mode this value is always interpreted as an absolute value.

Object Description			
Index	Name	Object Type	Data Type
607A _h	Target Position	Variable	SIGNED32

Table 313: Object Description (607A_h in csp Mode)



Entry Description				
Sub-index	Access	PDO Mapping	Value Range	Default Value
0	rw	Refer to CiA402-3	SIGNED32	0

Table 314: Entry Description (607A_h in csp Mode)

9.1.8 Object 607D_h: Software Position Limit

This object indicates the configured maximal and minimal software position limits. These parameters define the absolute position limits for the position demand value and the position actual value. Every new target position is checked against these limits. The limit positions are always relative to the machine home position. Before being compared with the target position, they are corrected internally by the home offset as follows:

$$\text{Corrected_min_position_limit} = \text{min_position_limit} - \text{home_offset}$$

$$\text{Corrected_max_position_limit} = \text{max_position_limit} - \text{home_offset}$$

Object Description			
Index	Name	Object Type	Data Type
607D _h	Software Position Limit	Array	SIGNED32

Table 315: Object Description (607D_h)

Entry Description					
Sub-index	Description	Access	PDO Mapping	Value Range	Default Value
1	Minimum Position Limit	rw	no	SIGNED32	-2147483648
2	Maximum Position Limit	rw	no	SIGNED32	2147483647

Table 316: Entry Description (607D_h)

9.1.9 Object 60B0_h: Position Offset

This object provides an offset to the target position (object 607A_h, see section 9.1.7). The value is given in microsteps and will be added to the target position.

Object Description			
Index	Name	Object Type	Data Type
60B0 _h	Offset Torque	Variable	INTEGER32

Table 317: Object Description (60B0_h)

Entry Description				
Sub-index	Access	PDO Mapping	Value Range	Default Value
0	rw	yes	-2147483648...2147483647	0

Table 318: Entry Description (60B0_h)

9.1.10 Object 60C2_h: Interpolation Time Period

This object indicates the interpolation cycle time. The interpolation time period (sub-index 01_h) is given in $10^{\text{interpolation_time_index}}$ s. The interpolation time index (sub-index 02_h) is dimensionless.

Object Description			
Index	Name	Object Type	Data Type
60C2 _h	Offset Torque	Vecord	Interpolation time period record (0080 _h)

Table 319: Object Description (60C2_h)

Entry Description					
Sub-index	Description	Access	PDO Mapping	Value Range	Default Value
0	Highest sub-index supported	ro	no	UNSIGNED8	2
1	Interpolation time period value	rw	no	UNSIGNED8	1
2	Interpolation time index	rw	no	-3...3	-3

Table 320: Entry Description (60C2_h)

10 Cyclic synchronous Torque Mode

The cyclic synchronous torque mode is used to directly control the torque of the motor, without the need for position or velocity control. It contains limit functions, but not a trajectory generator. The cyclic synchronous torque mode covers the following sub-functions:

- Demand value input directly via an object.
- Monitoring of the torque.
- Limiting the position using the software limits or the hardware limit switches.

10.1 Detailed Object Specifications

10.1.1 Object 6040_n: Control Word

This object indicates the received command controlling the power drive system finite state automaton (PDS FSA). The CiA-402 state machine can be controlled using this object. Please refer to figure 5 for detailed information. The cyclic synchronous torque mode does not use any mode specific bits of the control word.

Structure of the control word									
15	9	8	7	6	4	3	2	1	0
nu	h	fr	nu	eo	qs	ev	so		
MSB					LSB				

Legend: nu=not used; h=halt; fr=fault reset; eo=enable operation; qs=quick stop; ev=enable voltage; so=switch on.

Table 321: Structure of the Control Word in cst Mode

Command coding						
Command	Bits of control word					Transitions
	Bit 7	Bit 3	Bit 2	Bit 1	Bit 0	
Shutdown	0	x	1	1	0	2,6,8
Switch on	0	0	1	1	1	3
Switch on & enable operation	0	1	1	1	1	3, 4
Disable voltage	0	x	x	0	x	7,9,10,12
Quick stop	0	x	0	1	x	7,10,11
Disable operation	0	0	1	1	1	5
Enable operation	0	1	1	1	1	4, 16
Fault reset	0-to-1	x	x	x	x	15

Table 322: Command Coding



Object Description			
Index	Name	Object Type	Data Type
6040 _h	Controlword	Variable	UNSIGNED16

Table 323: Object Description (6040_h in cst Mode)

Entry Description				
Sub-index	Access	PDO Mapping	Value Range	Default Value
0	rw	see CiA402-3	See command coding above.	

Table 324: Entry Description (6040_h in cst Mode)

10.1.2 Object 6041_h: Status Word

This object provides the status of the PDS FSA. It reflects the status of the CiA-402 state machine. Please refer to figure 5 for detailed information. The object is structured as defined below.

For more information about the coding please refer to the CANopen Drives and motion control device profile, part 2.

Structure of the Status Word															
15	14	13	12	11	10	9	8	7	6	5	4	3	2	1	0
dir	mot	oms	ila	r	rm	ms	w	sod	qs	ve	f	oe	so	rtso	
MSB														LSB	

Legend: nu=not used; r=reserved; oms=operation mode specific; h=halt; fr=fault reset; eo=enable operation; qs=quick stop; ev=enable voltage; so=switch on.

Table 325: Structure of the Status Word in cst Mode

Trinamic Specific Bits		
Bit	Name	Definition
14	Motor activity	0: Motor stands still. 1: Motor rotates.
15	Direction of rotation	This bit shows the direction of rotation.

Table 326: Trinamic Specific Bits



Operation Mode specific Bits in cst Mode		
Bit	Name	Definition
10	Reserved	Not used.
12	Target torque ignored	0: Target torque ignored. 1: Target torque used as input to control loop.
13	Reserved	Not used.

Table 327: Operation Mode specific Bits in cst Mode

State Coding	
Status word	FSA state
xxxx xxxx x0xx 0000 _h	Not ready to switch on
xxxx xxxx x1xx 0000 _h	Switch on disabled
xxxx xxxx x01x 0001 _h	Ready to switch on
xxxx xxxx x01x 0011 _h	Switched on
xxxx xxxx x01x 0111 _h	Operation enabled
xxxx xxxx x00x 0111 _h	Quick stop active
xxxx xxxx x0xx 1111 _h	Fault reaction active
xxxx xxxx x0xx 1000 _h	Fault

Table 328: State Coding

Object Description			
Index	Name	Object Type	Data Type
6041 _h	Controlword	Variable	UNSIGNED16

Table 329: Object Description (6041_h in cst Mode)

Entry Description				
Sub-index	Access	PDO Mapping	Value Range	Default Value
0	rw	see CiA402-3	See state coding above	

Table 330: Entry Description (6041_h in cst Mode)

10.1.3 Object 6062_h: Position Demand Value

This object provides the demanded position value. The value is given in microsteps. Object 6062_h indicates the actual position that the motor should have. It is not to be confused with objects 6063_h and 6064_h.



Object Description			
Index	Name	Object Type	Data Type
6062 _h	Position Demand Value	Variable	SIGNED32

Table 331: Object Description (6062_h)

Entry Description				
Sub-index	Access	PDO Mapping	Value Range	Default Value
0	ro	Refer to CiA402-3	SIGNED32	no

Table 332: Entry Description (6062_h)

10.1.4 Object 6063_h: Position Actual Internal Value

This object provides the actual value of the encoder or the motor. Please use the sensor selection object 606A_h (see section 5.1.8) for selecting the motor or the encoder first. Object 6063_h indicates the actual position of the encoder or the motor, re-scaled to the microstep resolution. The value is given in microsteps.

Object Description			
Index	Name	Object Type	Data Type
6063 _h	Position Actual Internal Value	Variable	SIGNED32

Table 333: Object Description (6063_h)

Entry Description				
Sub-index	Access	PDO Mapping	Value Range	Default Value
0	ro	Refer to CiA402-3	SIGNED32	no

Table 334: Entry Description (6063_h)

10.1.5 Object 6064_h: Position Actual Internal Value

This object provides the actual value of the position measurement device. It always contains the same value as object 6063_h.

Object Description			
Index	Name	Object Type	Data Type
6064 _h	Position Actual Internal Value	Variable	SIGNED32

Table 335: Object Description (6064_h)

Entry Description				
Sub-index	Access	PDO Mapping	Value Range	Default Value
0	ro	Refer to CiA402-3	SIGNED32	no

Table 336: Entry Description (6064_h)

10.1.6 Object 6071_h: Target Torque

This object sets the desired torque value. The value is given in mA.

Object Description			
Index	Name	Object Type	Data Type
6071 _h	Target torque	Variable	INTEGER16

Table 337: Object Description (6071_h)

Entry Description				
Sub-index	Access	PDO Mapping	Value Range	Default Value
0	rw	yes	-32768... 32767	0

Table 338: Entry Description (6071_h)

10.1.7 Object 6077_h: Torque actual Value

This object provides the actual torque value. The value is given in mA.

Object Description			
Index	Name	Object Type	Data Type
6077 _h	Torque actual Value	Variable	INTEGER16

Table 339: Object Description (6077_h)

Entry Description				
Sub-index	Access	PDO Mapping	Value Range	Default Value
0	ro	yes	-32768... 32767	0

Table 340: Entry Description (6077_h)

10.1.8 Object 607D_h: Software Position Limit

This object indicates the configured maximal and minimal software position limits. These parameters define the absolute position limits for the position demand value and the position actual value. Every new



target position is checked against these limits. The limit positions are always relative to the machine home position. Before being compared with the target position, they are corrected internally by the home offset as follows:

$$\begin{aligned} \text{Corrected_min_position_limit} &= \text{min_position_limit} - \text{home_offset} \\ \text{Corrected_max_position_limit} &= \text{max_position_limit} - \text{home_offset} \end{aligned}$$

Object Description			
Index	Name	Object Type	Data Type
607D _h	Software Position Limit	Array	SIGNED32

Table 341: Object Description (607D_h)

Entry Description					
Sub-index	Description	Access	PDO Mapping	Value Range	Default Value
1	Minimum Position Limit	rw	no	SIGNED32	-2147483648
2	Maximum Position Limit	rw	no	SIGNED32	2147483647

Table 342: Entry Description (607D_h)

10.1.9 Object 60B2_h: Torque Offset

This object provides an offset to the torque value. It will be added to the target torque (object 6071_h, see section 10.1.6).

Object Description			
Index	Name	Object Type	Data Type
60B2 _h	Offset Torque	Variable	INTEGER16

Table 343: Object Description (60B2_h)

Entry Description				
Sub-index	Access	PDO Mapping	Value Range	Default Value
0	rw	yes	-32768... 32767	0

Table 344: Entry Description (60B2_h)

10.1.10 Object 60C2_h: Interpolation Time Period

This object indicates the interpolation cycle time. The interpolation time period (sub-index 01_h) is given in 10^{interpolation_time_index} s. The interpolation time index (sub-index 02_h) is dimensionless.



Object Description			
Index	Name	Object Type	Data Type
60C2 _h	Offset Torque	Vecord	Interpolation time period record (0080 _h)

Table 345: Object Description (60C2_h)

Entry Description					
Sub-index	Description	Access	PDO Mapping	Value Range	Default Value
0	Highest sub-index supported	ro	no	UNSIGNED8	2
1	Interpolation time period value	rw	no	UNSIGNED8	1
2	Interpolation time index	rw	no	-3...3	-3

Table 346: Entry Description (60C2_h)



11 Emergency Messages (EMCY)

The module sends an emergency message if an error occurs. The message contains information about the error type. The module can map internal errors and object 1001_h (error register) is part of every emergency object.

Emergency Messages (EMCY) of the TMCM-1310						
Error code	Additional byte					Description
	1	2	3	4	5	
0000 _h	0	0	0	0	0	Fault reset The fault reset command has been executed.
1000 _h	1	0	0	0	0	Generic error: open load bridge A The motor driver indicates open load on bridge A. It is possible that the motor cable is broken or that there is an error in the power amplifier itself.
1000 _h	2	0	0	0	0	Generic error: open load bridge B The motor driver indicates open load on bridge B. It is possible that the motor cable is broken or that there is an error in the power amplifier itself.
2310 _h	0	0	0	0	0	Overcurrent high side The motor driver indicates an overcurrent on the high side. This can be caused by a short circuit in the driver stage.
2311 _h	0	0	0	0	0	Overcurrent bridge B The motor driver indicates that there is overcurrent on bridge B. This can be caused by a short circuit in the motor itself or in the motor driver stage.
2312 _h	0	0	0	0	0	Overcurrent bridge A The motor driver indicates that there is overcurrent on bridge A. This can be caused by a short circuit in the motor itself or in the motor driver stage.
3230 _h	0	0	0	0	0	stallGuard2 error The actual load value exceeds the stallGuard2 limit.
4310 _h	1	0	0	0	0	Overtemperature pre-warning The temperature in the motor driver exceeds the pre-warning limit.
4310 _h	2	0	0	0	0	Overtemperature error The motor driver has been switched off because the temperature limit has been exceeded.
5441 _h	0	255	0	0	0	Shutdown switch active The enable signal is missing (due to the shutdown switch) and the motor driver has been switched off.
6320 _h	0	255	0	0	0	Parameter error The data in the received PDO is either wrong or cannot be accepted due to the internal state of the drive.



Error code	Additional byte					Description
	1	2	3	4	5	
8611 _h	0	0	0	0	0	Following error The deviation between motor position counter and encoder position counter has exceeded the following error window.
ff00 _h	0	0	0	0	0	Undervoltage The supply voltage is too low to drive a motor.
ff01 _h	1	0	0	0	0	Positive software limit The actual position is outside the range defined by object 607d _h .
ff01 _h	2	0	0	0	0	Negative software limit The actual position is outside the range defined by object 607d _h .
ff01 _h	3	0	0	0	0	Positive limit switch The positive limit switch has been touched outside of the homing function.
ff01 _h	4	0	0	0	0	Negative limit switch The negative limit switch has been touched outside of the homing function.

Table 347: Emergency Messages (EMCY)



12 Figures Index

1	NMT State Machine	10	7	Homing Method 1	84
2	Device Model	11	8	Homing Method 2	85
3	coolStep Adjustment Points and Thresholds	21	9	Homing Method 3	85
4	Brake Output Timing	24	10	Homing Method 5	86
5	DS402 Finite State Machine	63	11	Homing Method 19	86
6	Homing Mode Function	83	12	Homing Methods 33 and 34	87
			13	Home Offset	91



13 Tables Index

1	Abbreviations used in this Manual . . .	7	53	Entry Description (2021 _h)	28
2	Service Primitives	8	54	Object Description (2022 _h)	28
3	Service Types	9	55	Entry Description (2022 _h)	28
4	Object Dictionary	12	56	Object Description (2023 _h)	29
5	Object Description (1000 _h)	13	57	Entry Description (2023 _h)	29
6	Entry Description (1000 _h)	13	58	Object Description (2024 _h)	29
7	Object Description (1001 _h)	13	59	Entry Description (2024 _h)	29
8	Entry Description (1001 _h)	13	60	Object Description (2025 _h)	29
9	Error Register Bits	14	61	Entry Description (2025 _h)	30
10	Object Description (1008 _h)	14	62	Object Description (2026 _h)	30
11	Entry Description (1008 _h)	14	63	Entry Description (2026 _h)	30
12	Object Description (1009 _h)	14	64	Object Description (2027 _h)	30
13	Entry Description (1009 _h)	15	65	Entry Description (2027 _h)	30
14	Object Description (100A _h)	15	66	Object Description (2028 _h)	31
15	Entry Description (100A _h)	15	67	Entry Description (2028 _h)	31
16	Object Description (1018 _h)	15	68	Object Description (2029 _h)	31
17	Entry Description (1018 _h)	16	69	Entry Description (2029 _h)	31
18	Object Description (1600 _h)	16	70	Object Description (202A _h)	31
19	Entry Description (1600 _h)	16	71	Entry Description (202A _h)	32
20	Object Description (1A00 _h)	17	72	Object Description (2030 _h)	32
21	Entry Description (1A00 _h)	17	73	Entry Description (2030 _h)	32
22	Sync Manager Communication Types	18	74	Object Description (2031 _h)	32
23	Object Description (1C00 _h)	18	75	Entry Description (2031 _h)	32
24	Entry Description (1C00 _h)	18	76	Object Description (2032 _h)	33
25	Object Description (1C12 _h)	18	77	Entry Description (2032 _h)	33
26	Entry Description (1C12 _h)	19	78	Object Description (2033 _h)	33
27	Object Description (1C13 _h)	19	79	Entry Description (2033 _h)	33
28	Entry Description (1C13 _h)	19	80	Object Description (2034 _h)	33
29	Closed Loop / FOC2 related Objects	21	81	Entry Description (2034 _h)	34
30	coolStep related Objects	22	82	Object Description (2035 _h)	34
31	Object Description (2000 _h)	23	83	Entry Description (2035 _h)	34
32	Entry Description (2000 _h)	23	84	Object Description (2036 _h)	34
33	Object Description (2001 _h)	23	85	Entry Description (2036 _h)	34
34	Entry Description (2001 _h)	23	86	Object Description (2037 _h)	35
35	Object Description (2002 _h)	24	87	Entry Description (2037 _h)	35
36	Entry Description (2002 _h)	24	88	Object Description (2038 _h)	35
37	Object Description (2003 _h)	24	89	Entry Description (2038 _h)	35
38	Entry Description (2003 _h)	24	90	Object Description (2039 _h)	35
39	Object Description (2004 _h)	25	91	Entry Description (2039 _h)	36
40	Entry Description (2004 _h)	25	92	Object Description (203A _h)	36
41	Object Description (2005 _h)	25	93	Entry Description (203A _h)	36
42	Entry Description (2005 _h)	25	94	Object Description (203B _h)	36
43	Bit Definitions (2005 _h)	26	95	Entry Description (203B _h)	36
44	Object Description (200A _h)	26	96	Object Description (208C _h)	37
45	Entry Description (200A _h)	26	97	Entry Description (208C _h)	37
46	Object Description (200B _h)	26	98	Object Description (208E _h)	37
47	Entry Description (200B _h)	27	99	Entry Description (208E _h)	37
48	Object Description (200C _h)	27	100	Object Description (2092 _h)	38
49	Entry Description (200C _h)	27	101	Entry Description (2092 _h)	38
50	Object Description (2020 _h)	27	102	Object Description (2093 _h)	38
51	Entry Description (2020 _h)	28	103	Entry Description (2093 _h)	38
52	Object Description (2021 _h)	28	104	Object Description (2094 _h)	38



105	Entry Description (2094 _h)	39	159	Object Description (2705 _h)	52
106	Object Description (2095 _h)	39	160	Entry Description (2705 _h)	52
107	Entry Description (2095 _h)	39	161	Object Description (2706 _h)	52
108	Object Description (2096 _h)	39	162	Entry Description (2706 _h)	52
109	Entry Description (2096 _h)	40	163	Object Description (2707 _h)	53
110	Object Description (2097 _h)	40	164	Entry Description (2707 _h)	53
111	Entry Description (2097 _h)	40	165	Object Description (2708 _h)	53
112	Object Description (2098 _h)	40	166	Entry Description (2708 _h)	53
113	Entry Description (2098 _h)	41	167	Object Description (270E _h)	53
114	Object Description (2099 _h)	41	168	Entry Description (270E _h)	54
115	Entry Description (2099 _h)	41	169	Value Description (605A _h)	55
116	Object Description (209A _h)	41	170	Object Description (605A _h)	55
117	Entry Description (209A _h)	42	171	Entry Description (605A _h)	55
118	Object Description (209B _h)	42	172	Value Description (605B _h)	56
119	Entry Description (209B _h)	42	173	Object Description (605B _h)	56
120	Object Description (209C _h)	42	174	Entry Description (605B _h)	56
121	Entry Description (209C _h)	43	175	Value Description (605C _h)	56
122	Object Description (209D _h)	43	176	Object Description (605C _h)	56
123	Entry Description (209D _h)	43	177	Entry Description (605C _h)	57
124	Object Description (209E _h)	43	178	Value Description (605D _h)	57
125	Entry Description (209E _h)	44	179	Object Description (605D _h)	57
126	Object Description (209F _h)	44	180	Entry Description (605D _h)	57
127	Entry Description (209F _h)	44	181	Value Description (605E _h)	57
128	Object Description (20A0 _h)	44	182	Object Description (605E _h)	58
129	Entry Description (20A0 _h)	44	183	Entry Description (605E _h)	58
130	Object Description (20A1 _h)	45	184	Value Description (6060 _h)	58
131	Entry Description (20A1 _h)	45	185	Object Description (6060 _h)	58
132	Object Description (20A2 _h)	45	186	Entry Description (6060 _h)	59
133	Entry Description (20A2 _h)	45	187	Value Description (6061 _h)	59
134	Object Description (20A3 _h)	46	188	Object Description (6061 _h)	59
135	Entry Description (20A3 _h)	46	189	Entry Description (6061 _h)	59
136	Object Description (2100 _h)	46	190	Value Description (606A _h)	60
137	Entry Description (2100 _h)	46	191	Object Description (606A _h)	60
138	Object Description (2101 _h)	46	192	Entry Description (606A _h)	60
139	Entry Description (2101 _h)	47	193	Object Description (608F _h)	60
140	Driver Error Flags (2102 _h)	47	194	Entry Description (608F _h)	60
141	Object Description (2102 _h)	47	195	Object Description (60FD _h)	61
142	Entry Description (2102 _h)	47	196	Entry Description (60FD _h)	61
143	Object Description (2107 _h)	48	197	Value Definition (6502 _h)	61
144	Entry Description (2107 _h)	48	198	Object Description (6502 _h)	62
145	Object Description (210B _h)	48	199	Entry Description (6502 _h)	62
146	Entry Description (210B _h)	48	200	Structure of the Control Word in pp Mode	64
147	Object Description (2700 _h)	48	201	Operation Mode specific Bits in pp Mode	64
148	Entry Description (2700 _h)	49	202	Command Coding	64
149	Object Description (2701 _h)	49	203	Object Description (6040 _h in pp Mode)	65
150	Entry Description (2701 _h)	49	204	Entry Description (6040 _h in pp Mode)	65
151	Bit Definitions (2702 _h)	50	205	Structure of the Staus Word in pp Mode	65
152	Object Description (2702 _h)	50	206	Trinamic Specific Bits	65
153	Entry Description (2702 _h)	50	207	Operation Mode specific Bits in pp Mode	66
154	Bit Definitions (2703 _h)	50	208	State Coding	66
155	Object Description (2703 _h)	51	209	Object Description (6041 _h in pp Mode)	66
156	Entry Description (2703 _h)	51	210	Entry Description (6041 _h in pp Mode)	66
157	Object Description (2704 _h)	51	211	Object Description (6062 _h)	67
158	Entry Description (2704 _h)	51			



212	Entry Description (6062 _h)	67	265	Entry Description (6083 _h)	81
213	Object Description (6063 _h)	67	266	Object Description (6085 _h)	81
214	Entry Description (6063 _h)	67	267	Entry Description (6085 _h)	81
215	Object Description (6064 _h)	67	268	Object Description (60FF _h)	82
216	Entry Description (6064 _h)	68	269	Entry Description (60FF _h)	82
217	Object Description (6065 _h)	68	270	Supported CANopen Homing Methods	84
218	Entry Description (6065 _h)	68	271	Homing Methods 17 – 21	86
219	Object Description (6067 _h)	69	272	Structure of the Control Word in hm Mode	88
220	Entry Description (6067 _h)	69	273	Operation Mode specific Bits in hm Mode	88
221	Object Description (6068 _h)	69	274	Command Coding	88
222	Entry Description (6068 _h)	69	275	Object Description (6040 _h in hm Mode)	89
223	Object Description (606C _h)	69	276	Entry Description (6040 _h in hm Mode)	89
224	Entry Description (606C _h)	70	277	Structure of the Status Word in hm Mode	89
225	Object Description (607A _h in pp Mode)	70	278	Trinamic Specific Bits	89
226	Entry Description (607A _h in pp Mode)	70	279	Operation Mode specific Bits in hm Mode	90
227	Object Description (607D _h)	70	280	State Coding	90
228	Entry Description (607D _h)	71	281	Object Description (6041 _h in hm Mode)	90
229	Object Description (6081 _h)	71	282	Entry Description (6041 _h in hm Mode)	90
230	Entry Description (6081 _h)	71	283	Object Description (606C _h)	91
231	Object Description (6082 _h)	71	284	Entry Description (606C _h)	91
232	Entry Description (6082 _h)	71	285	Object Description (607C _h)	91
233	Object Description (6083 _h)	72	286	Entry Description (607C _h)	91
234	Entry Description (6083 _h)	72	287	Object Description (6098 _h)	92
235	Object Description (6084 _h)	72	288	Entry Description (6098 _h)	92
236	Entry Description (6084 _h)	72	289	Object Description (6099 _h)	92
237	Object Description (6085 _h)	73	290	Entry Description (6099 _h)	92
238	Entry Description (6085 _h)	73	291	Object Description (609A _h)	93
239	Bit Definitions of Object 60F2 _h	73	292	Entry Description (609A _h)	93
240	Object Description (60F2 _h)	73	293	Object Description (2100 _h)	93
241	Entry Description (60F2 _h)	73	294	Entry Description (2100 _h)	93
242	Structure of the Control Word in pv Mode	75	295	Structure of the Control Word in csp Mode	95
243	Command Coding	76	296	Command Coding	96
244	Object Description (6040 _h in pv Mode)	76	297	Object Description (6040 _h in csp Mode)	96
245	Entry Description (6040 _h in pv Mode)	76	298	Entry Description (6040 _h in csp Mode)	96
246	Structure of the Status Word in pv Mode	76	299	Structure of the Status Word in csp Mode	96
247	Trinamic Specific Bits	77	300	Trinamic Specific Bits	97
248	Operation Mode specific Bits in pv Mode	77	301	Operation Mode specific Bits in csp Mode	97
249	State Coding	77	302	State Coding	97
250	Object Description (6041 _h in pv Mode)	77	303	Object Description (6041 _h in csp Mode)	97
251	Entry Description (6041 _h in pv Mode)	78	304	Entry Description (6041 _h in csp Mode)	98
252	Object Description (6062 _h)	78	305	Object Description (6062 _h)	98
253	Entry Description (6062 _h)	78	306	Entry Description (6062 _h)	98
254	Object Description (6063 _h)	78	307	Object Description (6063 _h)	98
255	Entry Description (6063 _h)	78	308	Entry Description (6063 _h)	98
256	Object Description (6064 _h)	79	309	Object Description (6064 _h)	99
257	Entry Description (6064 _h)	79	310	Entry Description (6064 _h)	99
258	Object Description (6065 _h)	79	311	Object Description (606C _h)	99
259	Entry Description (6065 _h)	79	312	Entry Description (606C _h)	99
260	Object Description (606C _h)	80			
261	Entry Description (606C _h)	80			
262	Object Description (607D _h)	80			
263	Entry Description (607D _h)	80			
264	Object Description (6083 _h)	81			



313	Object Description (607A _h in csp Mode)	99	331	Object Description (6062 _h)	105
314	Entry Description (607A _h in csp Mode)	100	332	Entry Description (6062 _h)	105
315	Object Description (607D _h)	100	333	Object Description (6063 _h)	105
316	Entry Description (607D _h)	100	334	Entry Description (6063 _h)	105
317	Object Description (60B0 _h)	100	335	Object Description (6064 _h)	105
318	Entry Description (60B0 _h)	101	336	Entry Description (6064 _h)	106
319	Object Description (60C2 _h)	101	337	Object Description (6071 _h)	106
320	Entry Description (60C2 _h)	101	338	Entry Description (6071 _h)	106
321	Structure of the Control Word in cst Mode	102	339	Object Description (6077 _h)	106
322	Command Coding	102	340	Entry Description (6077 _h)	106
323	Object Description (6040 _h in cst Mode)	103	341	Object Description (607D _h)	107
324	Entry Description (6040 _h in cst Mode)	103	342	Entry Description (607D _h)	107
325	Structure of the Status Word in cst Mode	103	343	Object Description (60B2 _h)	107
326	Trinamic Specific Bits	103	344	Entry Description (60B2 _h)	107
327	Operation Mode specific Bits in cst Mode	104	345	Object Description (60C2 _h)	108
328	State Coding	104	346	Entry Description (60C2 _h)	108
329	Object Description (6041 _h in cst Mode)	104	347	Emergency Messages (EMCY)	110
330	Entry Description (6041 _h in cst Mode)	104	348	Firmware Revision	118
			349	Document Revision	118



14 Supplemental Directives

14.1 Producer Information

14.2 Copyright

TRINAMIC owns the content of this user manual in its entirety, including but not limited to pictures, logos, trademarks, and resources. © Copyright 2016 TRINAMIC. All rights reserved. Electronically published by TRINAMIC, Germany.

Redistributions of source or derived format (for example, Portable Document Format or Hypertext Markup Language) must retain the above copyright notice, and the complete Datasheet User Manual documentation of this product including associated Application Notes; and a reference to other available product-related documentation.

14.3 Trademark Designations and Symbols

Trademark designations and symbols used in this documentation indicate that a product or feature is owned and registered as trademark and/or patent either by TRINAMIC or by other manufacturers, whose products are used or referred to in combination with TRINAMIC's products and TRINAMIC's product documentation.

This CoE Firmware Manual is a non-commercial publication that seeks to provide concise scientific and technical user information to the target user. Thus, trademark designations and symbols are only entered in the Short Spec of this document that introduces the product at a quick glance. The trademark designation /symbol is also entered when the product or feature name occurs for the first time in the document. All trademarks and brand names used are property of their respective owners.

14.4 Target User

The documentation provided here, is for programmers and engineers only, who are equipped with the necessary skills and have been trained to work with this type of product.

The Target User knows how to responsibly make use of this product without causing harm to himself or others, and without causing damage to systems or devices, in which the user incorporates the product.

14.5 Disclaimer: Life Support Systems

TRINAMIC Motion Control GmbH & Co. KG does not authorize or warrant any of its products for use in life support systems, without the specific written consent of TRINAMIC Motion Control GmbH & Co. KG.

Life support systems are equipment intended to support or sustain life, and whose failure to perform, when properly used in accordance with instructions provided, can be reasonably expected to result in personal injury or death.

Information given in this document is believed to be accurate and reliable. However, no responsibility is assumed for the consequences of its use nor for any infringement of patents or other rights of third parties which may result from its use. Specifications are subject to change without notice.

14.6 Disclaimer: Intended Use

The data specified in this user manual is intended solely for the purpose of product description. No representations or warranties, either express or implied, of merchantability, fitness for a particular purpose



or of any other nature are made hereunder with respect to information/specification or the products to which information refers and no guarantee with respect to compliance to the intended use is given.

In particular, this also applies to the stated possible applications or areas of applications of the product. TRINAMIC products are not designed for and must not be used in connection with any applications where the failure of such products would reasonably be expected to result in significant personal injury or death (safety-Critical Applications) without TRINAMIC's specific written consent.

TRINAMIC products are not designed nor intended for use in military or aerospace applications or environments or in automotive applications unless specifically designated for such use by TRINAMIC. TRINAMIC conveys no patent, copyright, mask work right or other trade mark right to this product. TRINAMIC assumes no liability for any patent and/or other trade mark rights of a third party resulting from processing or handling of the product and/or any other use of the product.

14.7 Collateral Documents & Tools

This product documentation is related and/or associated with additional tool kits, firmware and other items, as provided on the product page at: www.trinamic.com.



15 Revision History

15.1 Firmware Revision

Version	Date	Description
2.05	2016-Sep-30	First release.

Table 348: Firmware Revision

15.2 Document Revision

Version	Date	Description
1.00	2016-Sep-30	First release.

Table 349: Document Revision

